

# A DEEP LEARNING FRAMEWORK FOR PREDICTING SIGNALS IN OFDM-NOMA WITH VARIOUS ALGORITHMS

Bibekananda Panda and Poonam Singh

Department of Electronics and Communication Engineering,  
National Institute of Technology Rourkela, Odisha, India  
[bibekananda\\_panda@nitrkl.ac.in](mailto:bibekananda_panda@nitrkl.ac.in), [psingh@nitrkl.ac.in](mailto:psingh@nitrkl.ac.in)

## ABSTRACT

*The non-orthogonal multiple access (NOMA) approaches have increasingly attracted much interest. It has also been a potential method for wireless communication systems beyond the fifth generation (5G). The successive interference cancellation (SIC) procedure in NOMA systems is often carried out at the receiver, where several users are sequentially decoded. The successful detection of prior users will significantly influence the detection accuracy due to the effects of interferences. A deep learning-based NOMA receiver is analyzed to detect signals for multiple users in a single application without determining channels. This paper analyzes deep learning (DL)- based receiver for NOMA signal detection concerning several DL-aided sequence layers-based algorithms and optimizers by training orthogonal frequency division multiplexing (OFDM) symbols. The simulation outcomes illustrate the various DL-based receiver characteristics using the traditional SIC approach. It also demonstrates that the effect of the different DL-based models is more predictable than the SIC approach.*

## KEYWORDS

NOMA, DNN, GRU, LSTM, Bi-LSTM

## 1. INTRODUCTION

System throughput and information transmission rate requirements are getting more demanding as communication technology develops. The NOMA schemes have been considered a viable multiple-access approach for future-generation (5G) wireless networks to intensify system throughput and spectrum efficiency. NOMA allows several users to simultaneously utilize similar frequency resources by multiplexing them in the code or power domain. To effectively use bandwidth resources, NOMA will enable users with poor channel circumstances to simultaneously distribute subcarriers to users with favorable channel conditions. The core premise behind NOMA is to employ SIC at the receiver for detection and superposition coding at the transmitter to allow multiple users to transmit data simultaneously. By channel state information (CSI), the SIC method decodes data from several users in reducing order of signal power [1]-[2]. Due to the potential for pilot symbols applied in channel estimation to interfere with signals from other users, obtaining CSI in NOMA is difficult. The feature of OFDM is that it makes better use of the spectrum by utilizing the orthogonality between subcarriers. The use of DL for OFDM system signal identification and channel estimation is examined in [3]. Deep learning models are trained offline to solve channel distortion using simulation data based on channel characteristics. Data that has been directly transmitted online is retrieved using this method. Channel estimation and signal identification in wireless communications with complex distortions and interferences can be performed using deep learning. Additionally, a cyclic prefix (CP) can be applied to reduce multi-path effect-related intersymbol interference (ISI) and

intercarrier interference (ICI). The OFDM-based-NOMA receiver detection design has been continually improved. As a detector based on a channel model, SIC must initially estimate the channel. Still, throughout information transmission, the pilot will be disrupted by signals from other users, making it impossible to get accurate channel state CSI. Furthermore, SIC will introduce a temporal delay while decoding users at a time. There may be a considerable performance reduction for conventional channel estimating techniques. Recently, deep learning has become quite popular in the wireless communication field. It uses an end-to-end approach to address wireless NOMA channels [4]-[5]. Model-driven deep learning is presented in [6], which offered additional learnable parameters for optimizing performance. In addition, OFDM-NOMA transmission increases system capacity. Based on early research in OFDM systems, the NOMA scheme's adaptation for DL-based applications provides numerous possibilities. The NOMA system uses a deep neural network (DNN) for signal detection [7]-[8]. A DNN is used to represent the NOMA receiver based on deep learning, which employs a completed connection layer and simultaneously detects all users. The training data is enormous, which lowers the detection efficiency even when the detection impact of DL is good. The performance of the receiver has been analyzed by using various deep learning-based sequential layers concerning different algorithms, such as the gated recurrent unit (GRU), bidirectional long short-term memory (Bi-LSTM), and long short-term memory (LSTM), along with various deep learning-based optimizers, such as root mean squared propagation (RMSProp), adaptive moment estimation (Adam), and stochastic gradient descent with momentum (SGDM). This study considers a DL-based NOMA receiver for an OFDM system with accessing data by several users to the same subchannel. DNNs are combined with the conventional SIC approach to detect multiple users by varying neural network parameters in a single operation.

The paper is structured as follows in the remaining sections. In Section II, the recommended system overview is explained. The different DL-based sequence layers with optimizers are highlighted in Section III. Section IV presents the simulation outcomes, and the conclusion and proposed directions for more study are included in Section V.

## 2. SYSTEM OVERVIEW

A two-user NOMA model based on an OFDM system is considered, and then the DL-based OFDM based-NOMA receiver, along with the different DL-network layers, is demonstrated.

### 2.1. System Model

NOMA is a multi-access technique for next-generation technology. NOMA technology allows users to transmit data across wireless channels while significantly conserving frequency resources. The multi-user uplink NOMA scenario in the OFDM system is considered, as depicted in Figure 1.

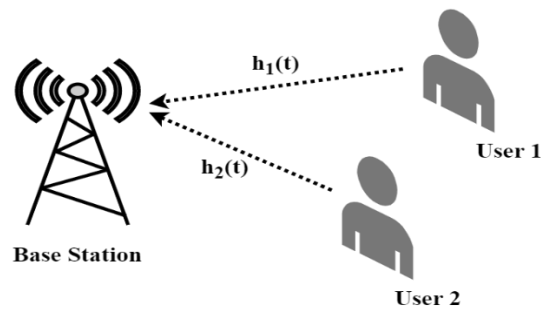

Figure 1. Two user uplink NOMA network

Here, all users use the same frequency resources simultaneously when they send data in this NOMA scenario. In addition to channel interference noise, the base station receives two users' superposition of data symbols. Multi-path propagation refers to the process by which signals travel along several pathways to reach the receiving end of a transmission that is influenced by many external factors. The power distribution is carried out under the assumption that both the transmitter and the receiver are aware of the CSI. The idea of power distribution is to give numerous users a reasonable signal to interference plus noised ratio (SINR) for cooperative decoding at the receiver [9].

By considering an  $N^{\text{th}}$  number of subcarriers OFDM systems with  $L$  users per subcarrier, the received signal on subcarrier  $t$  is illustrated as (1)

$$V(t) = \sum_{s=1}^L \sqrt{P_s(t)} H_s(t) U_s(t) + n(t) \quad (1)$$

where  $V(t)$  is the received signal,  $U_s(t)$  is the transmitted symbol, and  $n(t)$  is the additive white Gaussian noise (AWGN).

$P_s(t)$  is the transmitted power and the summation of all power coefficients is unity.

## 2.2. OFDM based-NOMA receiver with DNN

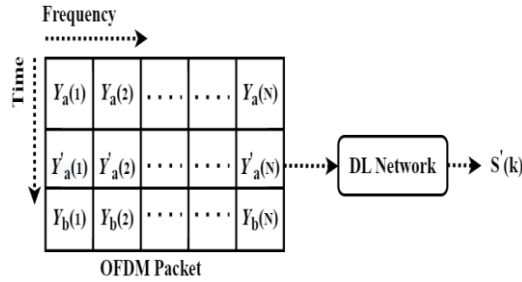

Figure 2. Receiver structure diagram based on DNN

The DNN implemented by the DL-based NOMA receiver is used to extract the transmitted symbols for both users in a single operation. In this paper, Figure 2 displays the receiver structure of the DL-based NOMA receiver for user detection, and Figure 3 shows the different layers of DNN. The DNN consists of 9 layers. The layers are an input layer, DL-based sequence layers (GRU, LSTM, Bi-LSTM), utility layers (dropout), activation layer (ReLU), softmax layer, and classification layer. In deep learning network layers, the DL-based sequence layer is the prime layer of the network. A network receives sequence data from the sequence input layer. GRU, LSTM, and Bi-LSTM are used as sequence layers to create a sequence input layer and set the input size property. The dropout layer is used for reducing overfitting in models. The Rectified Linear Unit (ReLU), followed by a softmax function, regulates neuron activity.

The receiver structure of the DNN based on an OFDM packet is also shown in Figure 2, where  $a$  and  $b$  stand for pilot and data symbols, respectively. The transmitted signals from two users are superimposed to form the OFDM symbol. Random symbols are produced in each simulation to create the OFDM packet with predetermined pilot sequences. A cyclic prefix (CP), which serves as the guard interval after the inverse DFT, is introduced between successive time domain OFDM signals. The CP must not be less than the channel impulse response to successfully prevent ISI. The OFDM packet is then sent across the available wireless channel. The base station will get the OFDM packets sent by the two users together with receiver noise. As a training sample for the DL-based network, this received OFDM packet is obtained by

generating a feature vector. The DNN can be trained to extract data from any subcarrier during training.

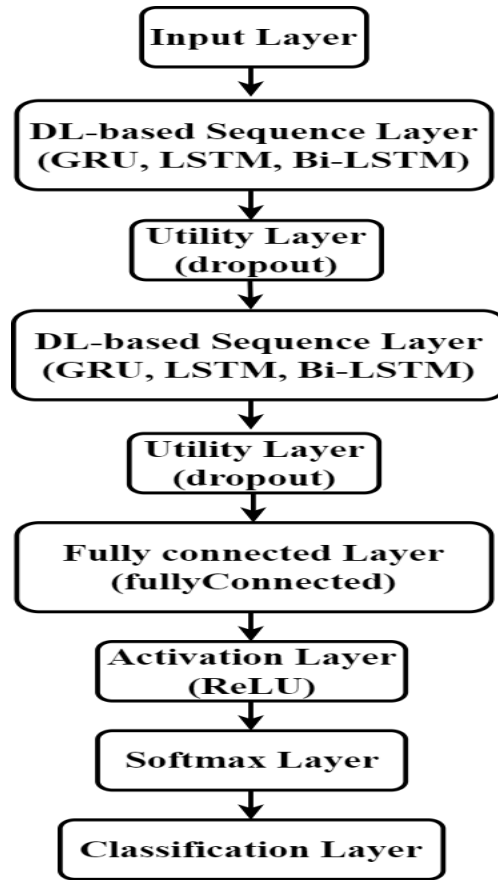

Figure 3. Deep learning network layers

### 3. DL-BASED SEQUENCE LAYERS WITH OPTIMIZERS

#### 3.1. DL-based sequence layers

Machine learning and deep learning techniques are the most efficient methods for time series prediction using statistical data. In terms of accuracy, these algorithms are comparable to traditional regression-based methods. The deep learning-based sequence layer outperforms conventional prediction techniques. These layer-based models are equipped with more "gates" so that they will take into consideration input data from longer sequences. Significant sequence layers for time series prediction include the gated-recurrent unit (GRU), long short-term memory (LSTM), and bidirectional long short-term memory (Bi-LSTM) [10]-[12].

### 3.1.1. Gated recurrent unit (GRU)

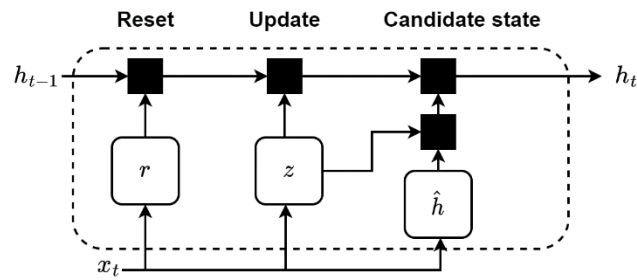

Figure 4. GRU sequence layer

Figure 4 demonstrates the GRU sequence layer. DL-based neural networks use the GRU layer as their gating mechanism. Since the GRU layer has no output gate, it has fewer features than an LSTM, but it is comparable to an LSTM with a forget gate. It consists of reset, update, and candidate state. The performance of GRU in many applications is comparable to LSTM. On some smaller, less frequently used datasets, GRUs have been proven to perform better. A unique aspect of GRU's architecture is that it combines input and forget gates into a single gate called an update gate. With certain adjustments, it also incorporates the secret state and cell state. Compared to LSTM, GRU has the advantage that it has fewer parameters without compromising accuracy, causing the model to converge more quickly.

### 3.1.2. Long short-term memory (LSTM) sequence layer

The LSTM sequence layer is shown in Figure 5. The primary purpose of employing neural networks is to store the information learned from previous data. However, owing to the minimal amount of information retained in memory, vanishing gradient problems are challenging. This issue is addressed with the introduction of LSTM.

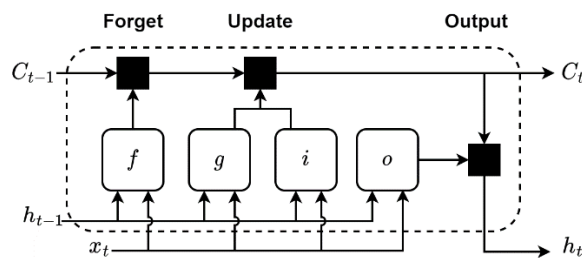

Figure 5. LSTM sequence layer

The LSTM models give the neural networks more memory to maintain and become aware of long-term input relationships. They can detect values, access information for a more extended period, and eliminate information from their memories due to this memory extension. The "gated" cells in LSTM memory are hence referred to as "gate" to specify whether memory material is to be retained or destroyed. The LSTM model accumulates the input characteristics and keeps them in memory for a long time. The weight values determined regarding the information are included throughout the training phase. The model learns whether data, facts, or statistics are vital to maintain or ignore because of predicting time series data. The model also comprises the input, forget, and output gates. The forget gate regulates whether existing information should be kept or erased, and the input gate determines the information to be added

to memory. A final output gate decides whether the cell's current value is incorporated into the output.

### 3.1.3. Bidirectional long short-term memory (Bi-LSTM) sequence layer

Bidirectional LSTMs, one of the LSTM models' extensions, can be used to process input files utilizing two LSTM models as shown in Figure 6. The sequence is supplied into the first forward layer of the LSTM model, and the second reverse layer of the LSTM model receives the input sequence in the opposite direction. After being used twice, the LSTM enhances the model's accuracy and the long-run training dependencies.

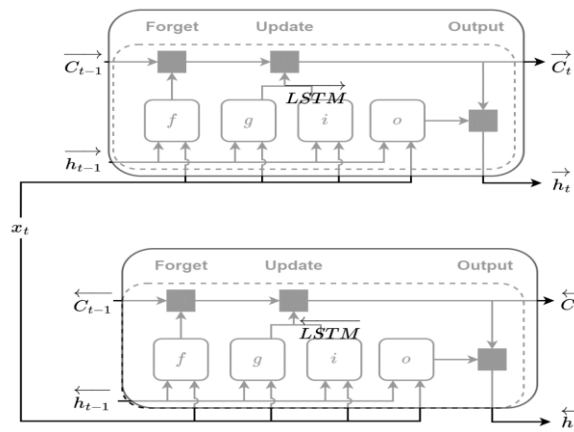

Figure 6. Bi-LSTM sequence layer

## 3.2. DL-based optimizers

The deep learning model comprises an input layer, activation, hidden layers, output layer, loss, etc. In DL-based models, different datasets are used to make predictions, and a different algorithm is used to normalize the data. The optimization method determines the weights or parameters whose values minimize the error in the input-to-output mapping. These optimization methods or optimizers significantly impact the effectiveness of the deep learning model. The weights for each epoch must be changed throughout the deep learning model's training process to reduce the loss function. An optimizer is a process or a technique that modifies the weights and learning rates of neural networks. This reduces overall loss and improves accuracy. Choosing the proper weights for a deep learning model might be challenging because these models can include millions of parameters. It illustrates the necessity of choosing appropriate optimization techniques for each operation [13]-[15]. The summary of various optimizers used in simulation work is listed below.

### 3.2.1. Stochastic Gradient Descent with Momentum (SGDM)

Gradient descent is an optimization technique that locates the minimal of an objective function by observing the negative gradient of the process. It has the drawback of bouncing around the search space on optimization problems with lots of curvature or unpredictable gradients and being stuck in flat regions of the search space with no gradient. Momentum is an addition to the gradient descent optimization process that enables the search to develop inertia in a direction in the search space, get around unpredictable gradient oscillations, and cruise over flat areas of the search space. Following the process's negative gradient may also find the minimum of an objective function. Gradient descent with momentum is the expansion of the gradient descent

optimization technique. This method aims to speed up the optimization process by reducing the number of function evaluations to reach an optimal result or to improve the functionality of the optimization algorithm to achieve a better outcome.

### 3.2.2. Root Mean Squared Propagation (RMSProp)

Root Mean Squared Propagation or RMSProp modifies gradient descent. A descending average of partial gradients is used in the Adagrad variant of gradient descent to adjust the step size for each parameter. Instead of considering the learning rate as a hyperparameter, RMSprop employs an adaptive learning rate. This implies that the degree of learning varies throughout time. The Adagrad principles are modified to allow the gradient to be accumulated. An exponentially weighted average is created from the gradients. RMSProp keeps only the most current gradient data and ignores the previous data. It also divides the learning rate by the average of the squared gradients, which decays exponentially.

### 3.2.3. Adaptive Moment Estimation (Adam)

An approach to gradient descent optimization is referred to as adaptive moment estimation. The method is incredibly effective when solving challenging problems requiring a lot of factors and data. It is practical and needs minimal memory. It also combines the "gradient descent with momentum" technique and the "RMSProp" algorithm by generating discrete learning rates for different parameters as an adaptive learning rate method.

## 4. SIMULATION RESULTS

The performance of the OFDM-based-NOMA receiver on different neural networks with different deep learning sequence layers is analyzed in this section.

The simulation parameters are listed in Table 1.

Table 1. Simulation Parameters

Parameters	Value
No. of Subcarriers	64
Length of cyclic prefix	16, 8
Number of users	2
DNN layer	1 (9x1 Layer)
Batch size	2000
Epochs	100
Learning rate	0.01
Training data	320000
DL-based sequence layer	GRU, LSTM, Bi-LSTM
DL-based optimizers	Adam, RMSProp, SGDM

The OFDM symbols are generated using the simulation parameters as per Table 1. It has assumed the cyclic prefixes (CP) as 16 and 8. Figure 7 and Figure 8 represent the BER performance for User 1 (U1) and User 2 (U2) for cyclic prefixes 16, respectively. The simulations also indicate the various deep learning-based sequence layer applications with DL-based optimizers concerning BER performance.

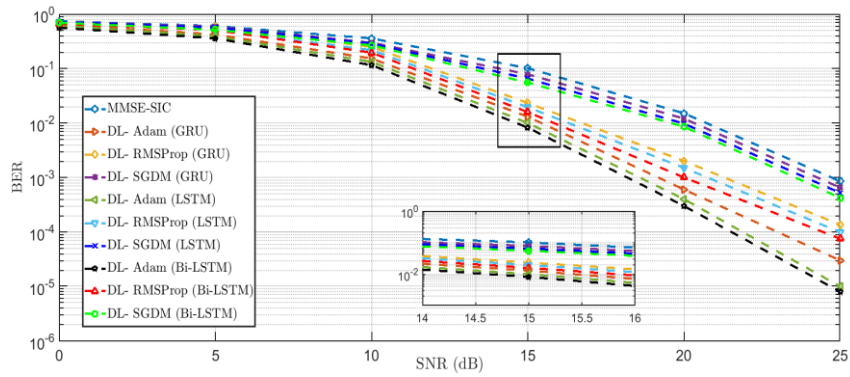

Figure 7. BER performance with cyclic prefix 16 for User 1

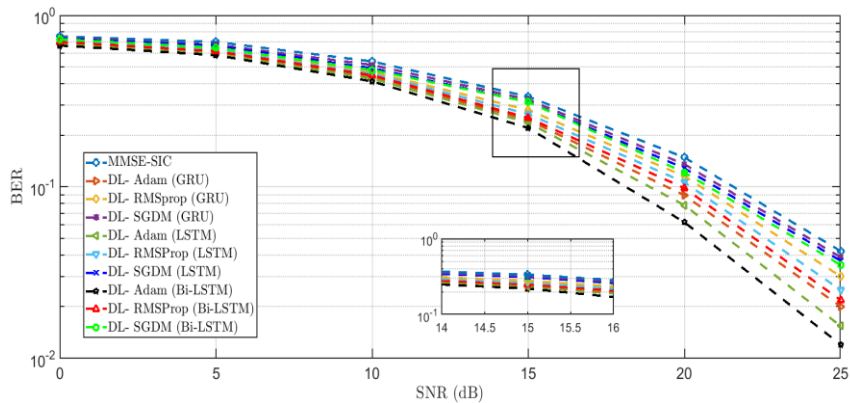

Figure 8. BER performance with cyclic prefix 16 for User 2

Similarly, it has considered a less cyclic prefix 8 for the simulation to analyze the performance of BER for different users. Figure 9 and Figure 10 show the BER performance of U1 and U2 for cyclic prefix 8 with varying layers of sequence and optimizers. The simulation curves show the BER performance of the conventional SIC- MMSE method with the different deep learning-based receiver approaches. The results indicate that the DL-based method is more robust to signal detection than the traditional SIC method.

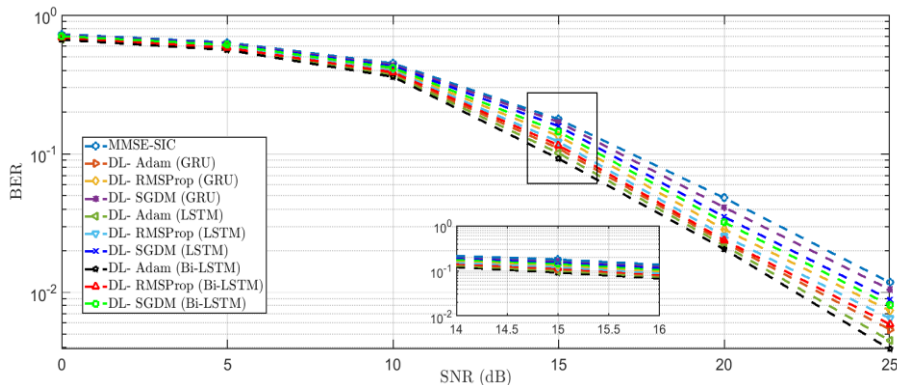

Figure 9. BER performance with cyclic prefix 8 for User 1



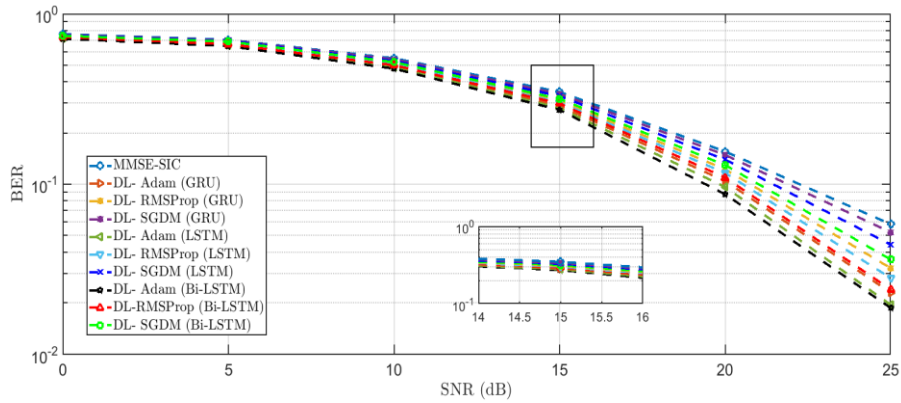

Figure 10. BER performance with cyclic prefix 8 for User 2

Here, Table 2 indicates the BER performance for a particular SNR 15 dB by assuming different sequence layers with different DL-based optimizers.

Table 2. BER performance for SNR 15 dB concerning different sequence layers with optimizers

Bit Error Rate (BER)				
User	U1	U1	U2	U2
Cyclic Prefix	16	8	16	8
SIC (MMSE)	0.101	0.177	0.335	0.347
SGDM (GRU)	0.078	0.169	0.322	0.338
SGDM (LSTM)	0.065	0.158	0.311	0.328
RMSProp (GRU)	0.0232	0.134	0.28	0.309
RMSProp (LSTM)	0.0194	0.122	0.265	0.301
RMSProp (Bi-LSTM)	0.0158	0.115	0.252	0.297
Adam (GRU)	0.013	0.109	0.245	0.288
Adam (LSTM)	0.01	0.101	0.236	0.279
Adam (Bi-LSTM)	0.0082	0.092	0.22	0.272

It illustrates that the DL-based receiver provides better BER performance than the traditional SIC receiver approach and that the Bi-LSTM with Adam sequence performs better than other sequence layers.

## 5. CONCLUSION

A preliminary analysis of DL for signal detection and channel estimation in a two-user OFDM-based NOMA system is presented in this work. It demonstrates the usage of several DL-based sequence layers with various optimizers. A deep learning-based NOMA receiver with a distinct neural network layer is considered to retrieve transmitted symbols for both users. Two cyclic prefixes (16, 8) have been considered in this work. Also, it is evaluated against three different DL optimization techniques, namely SGDM, RMSProp, and Adam, with various sequence algorithms, including GRU, LSTM, and Bi-LSTM. When BER is compared with Adam using Bi-LSTM models, it performs better than other models. Even with a short CP and severe ISI effects, the DL-based receiver performs better and can be superior to the MMSE-SIC receiver for the users. By learning channel properties, the DNN becomes more resilient to ISI-induced signal distortion. Additionally, it offers superior signal detection capability compared to the

MMSE-SIC receiver. Further study and analysis will be done for more advanced system models, such as massive MIMO and heterogeneous NOMA network applications.

## REFERENCES

- [1] B. Makki, K. Chitti, A. Behravan and M. -S. Alouini, (2020) "A Survey of NOMA: Current Status and Open Research Challenges", *IEEE Open Journal of the Communications Society*, Vol. 1, pp. 179-189.
- [2] B. Panda and P. Singh, (2021) "Performance Analysis of NOMA Systems in Rayleigh and Rician Fading Channels", *Advanced Communication Technologies and Signal Processing (ACTS)*, pp. 1-6.
- [3] H. Ye, G. Y. Li, and B. -H. Juang, (2018) "Power of Deep Learning for Channel Estimation and Signal Detection in OFDM Systems", *IEEE Wireless Communications Letters*, Vol. 7, no. 1, pp. 114-117.
- [4] F.-L. Luo, (2020) "Machine Learning for Future Wireless Communications", Wiley.
- [5] G. Gui, H. Huang, Y. Song, and H. Sari, (2018) "Deep Learning for an Effective Nonorthogonal Multiple Access Scheme," *IEEE Transactions on Vehicular Technology*, vol. 67, no. 9, pp. 8440-8450.
- [6] H. He, S. Jin, C.-K. Wen, F. Gao, G. Y. Li, and Z. Xu, (2019) "Model-driven deep learning for physical layer communications," *IEEE Wireless Commun.*, vol. 26, no. 5, pp. 77–83.
- [7] C. Lin, Q. Chang, and X. Li, (2019) "A deep learning approach for MIMO NOMA downlink signal detection," *Sensors*, vol. 19, no. 11: 2526.
- [8] Y. Xie, K. C. Teh and A. C. Kot, (2021) "Deep Learning-Based Joint Detection for OFDM-NOMA Scheme", *IEEE Communications Letters*, Vol. 25, no. 8, pp. 2609-2613.
- [9] Narengerile and J. Thompson, (2019) "Deep Learning for Signal Detection in Non-Orthogonal Multiple Access Wireless Systems", *UK/ China Emerging Technologies (UCET)*, pp. 1-4.
- [10] M. Pirani, P. Thakkar, P. Jivrani, M. H. Bohara, and D. Garg, (2022) "A Comparative Analysis of ARIMA, GRU, LSTM, and BiLSTM on Financial Time Series Forecasting", *IEEE International Conference on Distributed Computing and Electrical Circuits and Electronics (ICDCECE)*, pp. 1-6.
- [11] M. H. Essai Ali, M. L. Rabeh, S. Hekal, and A. N. Abbas, (2022) "Deep Learning Gated Recurrent Neural Network-Based Channel State Estimator for OFDM Wireless Communication Systems", *IEEE Access*, vol. 10, pp. 69312-69322.
- [12] M. Marei, W. Li, (2022) "Cutting tool prognostics enabled by hybrid CNN-LSTM with transfer learning", *The International Journal of Advanced Manufacturing Technology*, pp.817-836.
- [13] Sebastian Ruder, (2016) "An overview of gradient descent optimization algorithms", *ArXiv*, vol. abs/1609.04747.
- [14] E. M. Dogo, O. J. Afolabi, N. I. Nwulu, B. Twala and C. O. Aigbavboa, (2018) "A Comparative Analysis of Gradient Descent-Based Optimization Algorithms on Convolutional Neural Networks", *International Conference on Computational Techniques, Electronics and Mechanical Systems (CTEMS)*, pp. 92-99.
- [15] D. Soydaner, (2020) "A Comparison of Optimization Algorithms for Deep Learning", *International Journal of Pattern Recognition and Artificial Intelligence*, vol. 34.

## Authors

**Bibekananda Panda** received a B. Tech degree in Electronics and Communication Engineering (ECE) from Siksha 'O' Anusandhan University, Odisha, India in 2014, and an MTech degree in ECE from Biju Patnaik University of Technology, Odisha in 2016. He is currently pursuing a Ph.D. degree in the department of EC at the National Institute of Technology Rourkela, India. His research interests include resource allocation, power allocation, and signal detection based on deep learning techniques in wireless communications.

E-mail: bibekananda\_panda@nitrkl.ac.in



**Poonam Singh** received her B. Tech degree in Electronics and Tele-Communication Engineering from VSSUT, Burla, Odisha, India in 1988, MTech degree in Electronics Systems and Comm Engg. from National Institute of Technology, Rourkela, India in 1991, and Ph. D. from IIT Kharagpur in the field of Wireless Communications. Currently, she is a Professor in the Dept. of Electronics and Communication Engg. National Institute of Technology Rourkela, India. Her areas of interest are Wireless Communication, 5G and 6G Communication systems, Multicarrier MIMO, millimeter wave, and TeraHertz Comm, etc.

E-mail: psingh@nitrkl.ac.in

