

# Design of PFC Boost Converter with Stand-Alone Inverter for Microgrid Applications

Boddu Sujith

Department of Electrical Engineering  
National Institute of Technology  
Rourkela, India  
boddusujith197@gmail.com

Arnab Ghosh, *Senior Member, IEEE*

Department of Electrical Engineering  
National Institute of Technology  
Rourkela, India  
agghosh.ee@gmail.com

Vikash Gurugubelli, *Student Member, IEEE*

Department of Electrical Engineering  
National Institute of Technology  
Rourkela, India  
vikas0225@gmail.com

**Abstract**— The AC\AC converter described in this work can be employed in microgrids. The topology which is being brought forward is used to connect a single-phase renewable energy resource to the grid. The source is coupled to a single-phase PFC boost converter, which enhances the input power factor and maintains a regulated DC output voltage utilizing two feedback loops: outer voltage loop control and inner current loop control. The single-phase stand-alone inverter receives the output of the PFC boost converter. A symmetrical sinusoidal output voltage waveform should be produced and maintained by the inverter. The transformer receives the inverter's output and offers isolation between the grid and the source. The PFC boost converter receives the transformer's output. The stand-alone inverter connected to the grid receives the output of the PFC boost converter. The pulses for the switches in the single-phase inverter coupled standalone system was generated using a sinusoidal pulse width modulation approach. Current Mode Control is modelled for varied load fluctuations to ensure proper power flow from input to output. There are two feedback loops: an outer voltage feedback loop and an inside current feedback loop. The sinusoidal PWM approach is considered for generating the switching pulses to the stand-alone inverter. The simulation results are achieved by varying the load, maintaining a constant voltage and observing whether the current varies as the load changes.

**Keywords**—Power Factor Corrected (PFC), Stand-Alone Inverter, microgrid, Pulse width modulation (PWM).

## I. INTRODUCTION

The world is experiencing an energy crisis due to the rapidly dwindling of fossil fuels and an over-reliance on non-renewable sources. With the increased demand for electricity in recent years, power shortages have become a critical issue. Renewable energy resources are gaining traction as a result of their unique characteristics, which enable them to meet the ever-increasing demand. In comparison to traditional energy sources, they are inexpensive, long-lasting, and have lower operating costs. However, electric power is utilized and the sources from which the electric energy is acquired are many. Microgrids that include more than one type of electric power source are growing. Designing and controlling such hybrid systems optimally are of supreme importance. Interconnecting the microgrid to the distribution network requires proper control and management of the microgrid power flow. Such a requirement plays a pivotal

role that deciding how advantageous it is to interconnect a microgrid to the network.

When we select a ready-made uncontrolled source, we typically find a significant amount of inherited disturbance in it, which explains the conventional system's low power factor operation. In power electronic devices, a diode bridge rectifier converts alternating current to a constant DC current. Alternatively, this front-end converter insulates itself from high peaky and highly distorted grid current, resulting in a very low Power Factor and high Total Harmonic Distortion [1-5]. The Power Factor Correction circuit synchronizes the input voltage and current waveforms [6-10]. The passive PFC and the active PFC are the two main types of power factor correction technologies.

An inverter converts the signal from a dc power source to an AC one. A battery or rectifier can provide DC input [11-14]. Inverters can be classified as a square wave, quasi-square wave, or low distorted sine wave based on their output waveform. Due to their high Total Harmonic Distortion, square wave and quasi square waveforms are only suited for low and medium power applications; however, a higher quality waveform is required for high power applications [15-19]. The power quality of a sine wave is sometimes more important than its quantity. The use of correct PWM control systems helps reduce harmonic distortion [20-24].

There are six portions in this work. The first section is an introduction, the second section describes the proposed topology which contains the PFC boost converter and stand-alone inverter, the system parameters are mentioned in the third section, the fourth section contains the simulation results and the fifth section gives the conclusions of the topology discussed in the paper.

## II. TOPOLOGY OF PFC BOOST RECTIFIER WITH STAND-ALONE INVERTER

The topology consists of a PFC Boost rectifier, a stand-alone inverter, a transformer is used for variation in voltages and to provide isolation between source and grid. To get the controllable voltage, the output of the transformer is again fed to a single-phase PFC Boost rectifier, stand-alone inverter and the output is fed to the AC load bus as shown in Fig.1.

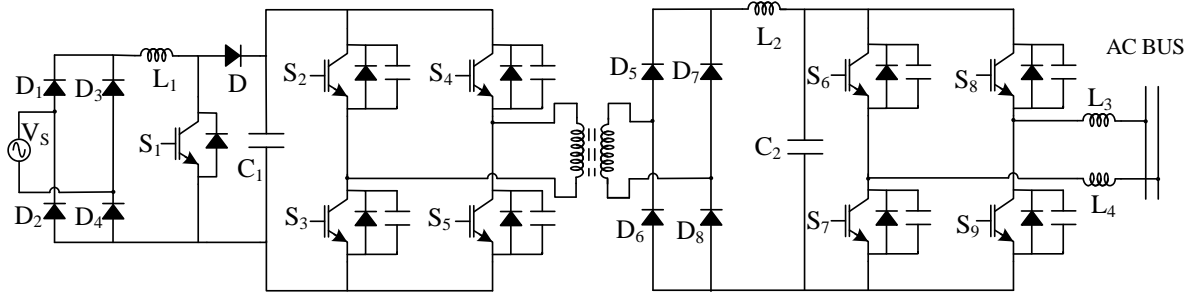

Fig. 1. PFC boost converter with the stand-alone inverter.

### A. Single-Phase PFC Boost Converter

Fig. 2 shows a single-phase diode bridge rectifier with a boost converter which is the key component of active PFC. Different converter topologies can theoretically be extended to the diode bridge rectifier and the dc-dc converter with filtering and energy storage capabilities. The boost design is rather simple, and it uses a variety of dedicated control techniques to achieve low-distorted input currents and a power factor of near unity. The output is also regulated by using the PFC boost converter.

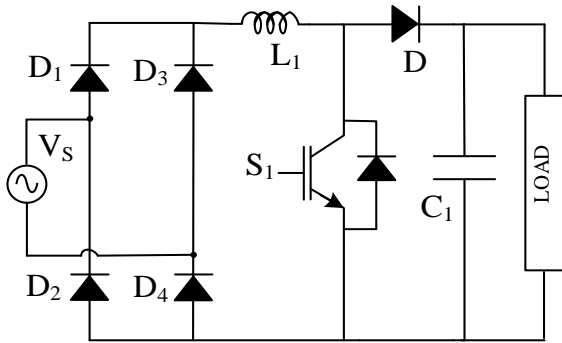

Fig 2. PFC Boost Converter.

Since the current always passes between the 3 semiconductor elements, which are the 2 diodes and the diode (or switch) S1, based on the situation of S1 whether it is on or off, the converter in Fig. 2 has significant conduction losses. As a result, the converter efficiency suffers, particularly at low input voltage. A high switching frequency is also expected to yield high power densities and quick transient responses from the converter. When the shift frequency of a hard-switching boost converter increases, the output diode acting at high voltage suffers respectable reverse recovery losses [5].

The switching pulses for the switch S1 are generated by using the controller block diagram as shown in Fig. 3.

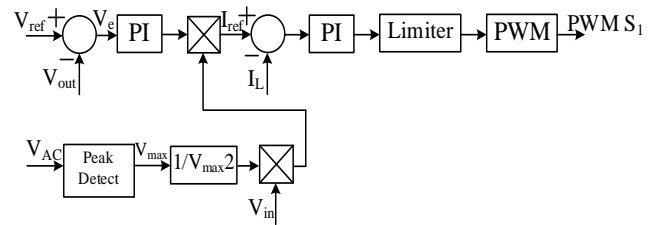

Fig. 3. Controller block diagram of PFC boost converter.

A sinusoidal reference for the current controller is generated by detecting the peak in the AC voltage waveform. Firstly, the voltage controller modifies the output voltage, and then the current controller maintains the sinusoidal wave shape and has control over the inductor current.[4] .

The reference current  $I_{ref}$  and feedback current  $I_L$  averaged over the per-switching period can be used to keep the switching frequency constant. Then  $I_L$  is compared with  $I_{ref}$ .

- If  $I_{ref} > I_L$ , then the duty cycle is more than 0.5
- If  $I_{ref} = I_L$ , then the duty cycle is equal to 0.5
- If  $I_{ref} < I_L$ , then the duty cycle is less than 0.5.

The inductor current is forced to stay between the maximum and minimum of the triangular waveform by following the reference sine wave, which is superimposed with a triangle waveform. The reference current  $I_{ref}$  is calculated using the error voltage  $V_e (= V_{ref} - V_{out})$  and the boost converter's input voltage  $V_{in}$ . The error of the  $I_{ref}$  and  $I_L$  is given to the PI controller which is followed by the limiter. The output of the limiter is given to the PWM generator which generates the pulses for the switch.

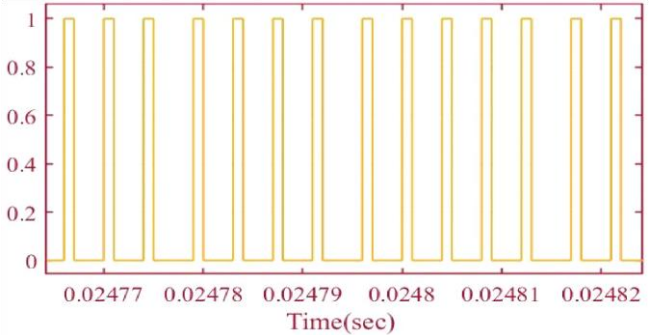

Fig. 4. Switching pulses of PFC boost converter.

### B. Single-Phase Stand-Alone Inverter

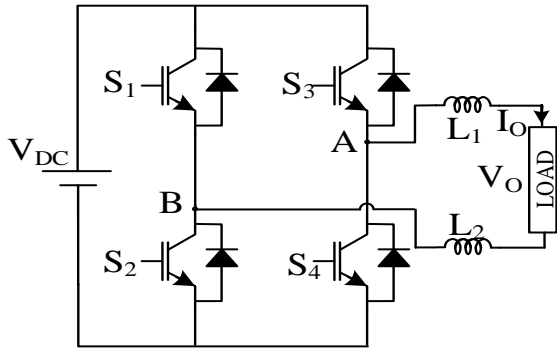

Fig. 5. Stand Alone Inverter

The legs A and B are switched according to its reference in the case of unipolar modulation. The following are the key characteristics of this converter:

- With mirrored sinusoidal reference, Leg A and Leg B are switched at a high frequency.
- S1, S3 = ON and S2, S4 = ON are the two possible zero output voltage states.

#### Operating Modes:

There are four operating modes as shown in the Table. 1

MODES	S <sub>1</sub>	S <sub>2</sub>	S <sub>3</sub>	S <sub>4</sub>	V <sub>O</sub>
1	0	1	1	0	+V <sub>DC</sub>
2	1	0	1	0	0
3	1	0	0	1	-V <sub>DC</sub>
4	0	1	0	1	0

Table. 1. Operating modes of Full- Bridge Inverter

Mode 1: The power semiconductor switches S2 and S3 are turned on in the positive active mode, while the remaining switches are turned off, resulting in an output voltage of V<sub>DC</sub>. The output current is positive throughout this time.

Mode 2: The power semiconductor switches S1 and S3 are turned on in the positive freewheeling mode, while the remaining switches are turned off, resulting in an output voltage of 0.

Mode 3: The power semiconductor switches S1 and S4 are turned on in the Negative active mode, while the remaining switches are turned off, resulting in a -V<sub>DC</sub> output voltage. The output current is negative while this is going on.

Mode 4: The power semiconductor switches S2 and S4 are turned on in the negative freewheeling mode, while the remaining switches are turned off, resulting in an output voltage of 0.

As a result, Mode 1 and Mode 3 are energy delivery stages, with energy from the source fed forward into the load. Modes 2

and 4 are freewheeling phases, and the energy from the AC filter is likewise discharged to the load.

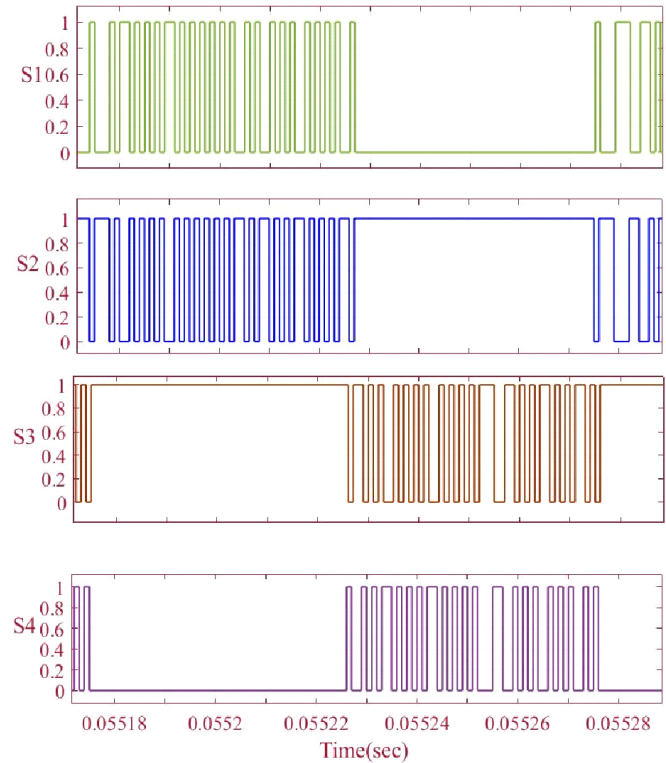

Fig. 6. Switching Pulses of Inverter

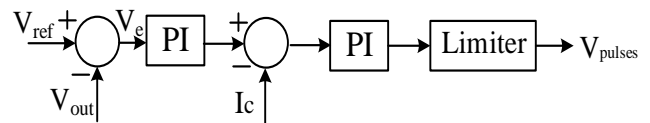

Fig. 7. Controller block diagram of the inverter.

The reference voltage to the PWM block is generated by using the controller block diagram as shown in Fig. 7.

First, we find the difference between the reference voltage (V<sub>ref</sub>) and the output voltage (V<sub>out</sub>). We have to properly set the amplitude and frequency of the reference voltage. Now the difference which is called the error is fed to a PI controller. The output of this gives a capacitor current. The capacitor current is compared with the actual capacitor current (I<sub>c</sub>) and the error is fed to the PI controller which gives a reference voltage (V<sub>pulses</sub>). The reference voltage is given to the PWM generation block.

The unipolar PWM technique is used for generating the switching pulses. In the unipolar PWM technique, we require two reference voltages that are out of phase with each other. The reference voltage is compared with the triangular carrier wave. The inverted and the non-inverted output of each comparator is given to each switch as shown in Fig.8

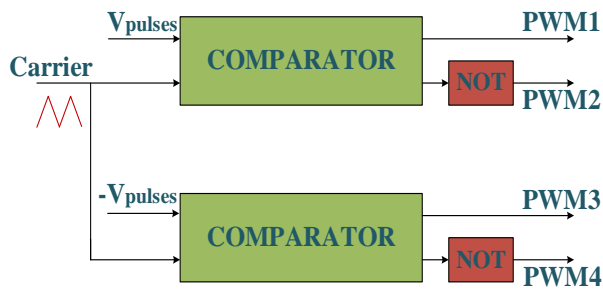

Fig. 8. Unipolar switching scheme

### III. SYSTEM PARAMETERS

Table. 2. Parameters of PFC boost converter.

Input Voltage(Vs)	230 V
Switching frequency	25 kHz
Boost inductor	0.3 mH
Capacitor	2000 $\mu$ F
Output Voltage	400 V

Table. 3. Parameters of stand-alone Inverter

Input Voltage	400 V
Filter Inductor	4 mH
Filter Capacitor	470 $\mu$ F
Output Voltage	240 V

### IV. SIMULATION RESULTS

According to the simulation result shown in Fig. 9, the source current and voltage are in phase. Consequently, the power factor increases.

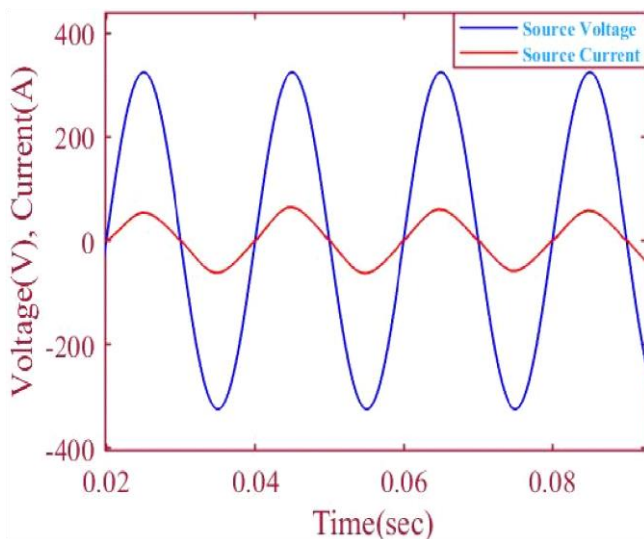

Fig. 9. Voltage and current waveforms of the source.

The source current waveform during constant load is shown in Fig. 10.

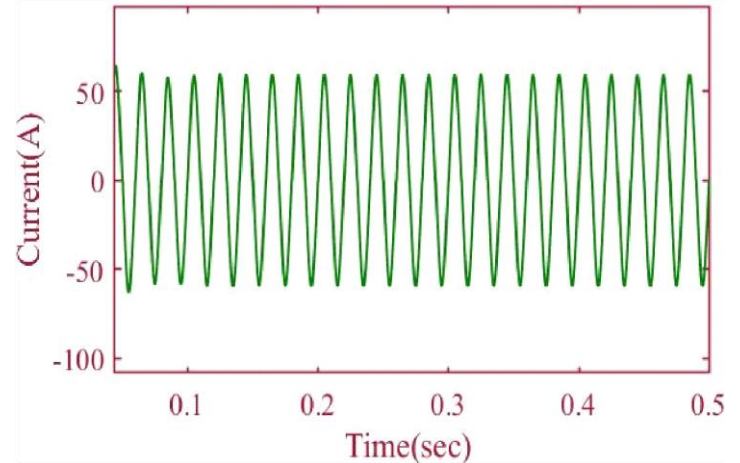

Fig. 10. Source current waveform with constant load.

The source current waveform when the load is varied is shown in Fig. 11.

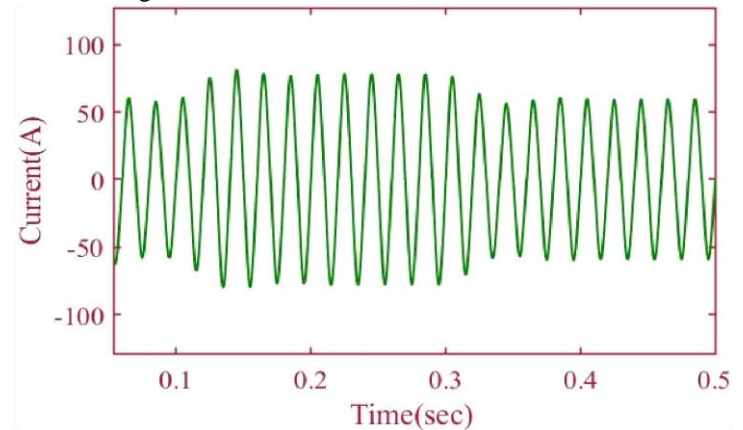

Fig. 11. Source current waveform due to load variations

The output voltage of a PFC Boost converter was simulated, and the outcome was shown in Fig. 12.

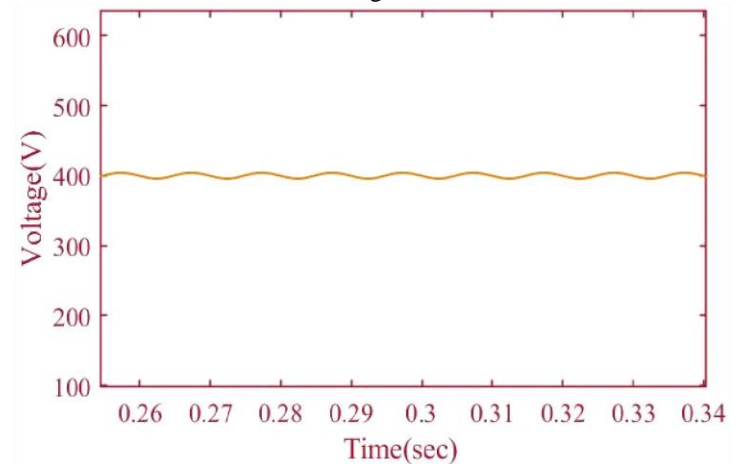

Fig. 12. The PFC boost converter's output voltage waveform

From the simulation result in Fig. 13, it is evident that the voltage is maintained constant.

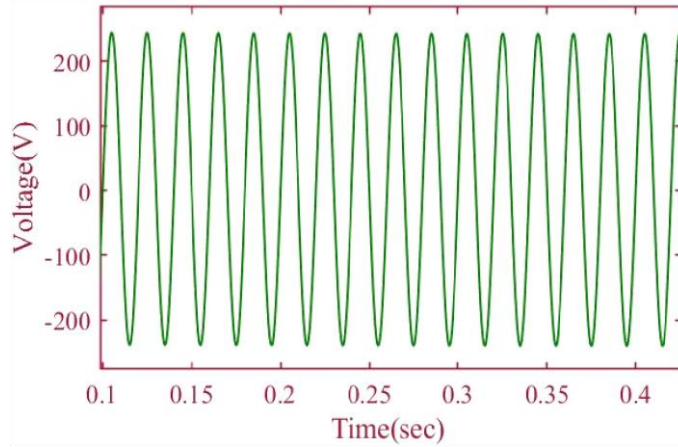

Fig. 13. The waveform of a stand-alone inverter's output voltage.

The output current waveform of the stand-alone inverter at constant load is shown in Fig. 14.

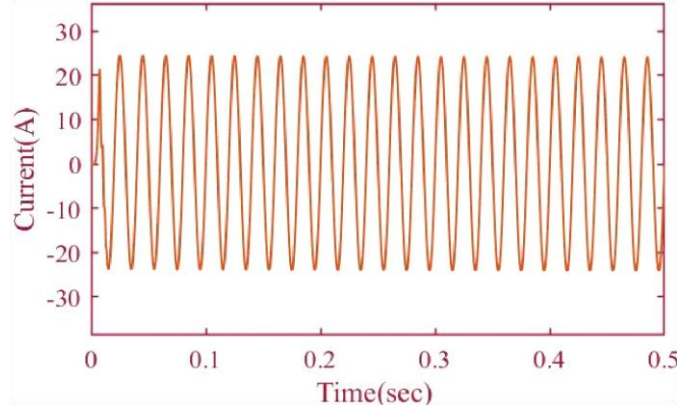

Fig. 14. Current waveform without any load variations

From the simulation, it is evident that the current is varying with the variations in the load.

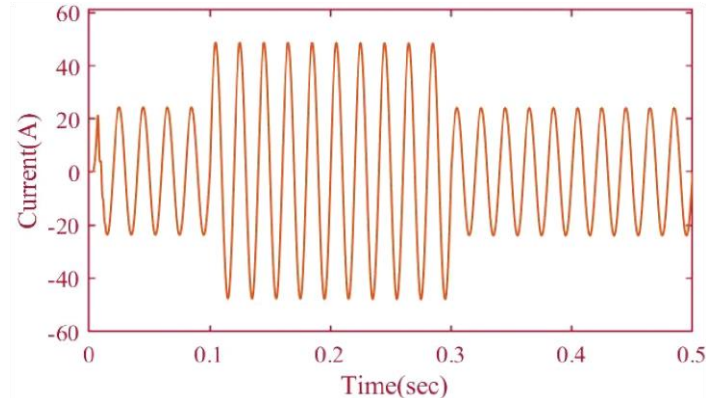

Fig. 15. Current waveform due to load variations

## V. CONCLUSION

In this paper, the working and the construction of the PFC boost converter in the closed-loop along with a stand-alone inverter in the closed-loop is discussed. The PFC boost converter is used to improve the input power factor of the converter and to maintain a regulated DC output voltage. The stand-alone inverter is used to maintain a symmetrical sinusoidal voltage irrespective of the load changes. The currents and the voltages of the PFC boost converter and stand-alone inverter with load changes are discussed. The simulation findings verify the topology approaches.

## VI. ACKNOWLEDGEMENT

The idea of work is supported by DST project (SP/YO/2019/1349)

## VII. REFERENCES

- [1] Philip, Riya, and C. Sreeja. "Single-phase PFC using Buck-Boost converter." In 2014 Annual International Conference on Emerging Research Areas: Magnetics, Machines and Drives (AICERA/iCMMD), pp. 1-5. IEEE, 2014.
- [2] Rong, Jun, Yuejiao Ding, Min Zhang, and Xi Chen. "Modeling and simulation of boost hard switching converter in power factor correction circuit." In 2013 3rd International Conference on Consumer Electronics, Communications and Networks, pp. 396-399. IEEE, 2013.
- [3] Prajapati, Manish, and Nair R. Viju. "Design Considerations in the Control of Single-Phase Boost Power Factor Corrected Rectifier for Utility Applications." In 2021 International Conference on Sustainable Energy and Future Electric Transportation (SEFET), pp. 1-6. IEEE, 2021.
- [4] Sankar, S.M. Padmarasan, T. Raghavi, and S. Saravana Kumar. "Simulation and design of closed-loop controlled PFC Boost Converter with EMI Filter." In 2013 7th International Conference on Intelligent Systems and Control (ISCO), pp. 3-6. IEEE, 2013.
- [5] J. P. M. Figueiredo, F. L. Tofoli and B. L. A. Silva, "A review of single-phase PFC topologies based on the boost converter," 2010 9th IEEE/IAS International Conference on Industry Applications - INDUSCON 2010, pp. 1-6, doi: 10.1109/INDUSCON.2010.5740015, 2010.
- [6] S.K. Sahoo and H.R. Jariwala, "A new power factor correction technique using PFC boost converter," 2012 11th International Conference on Environment and Electrical Engineering, pp. 819-823, doi:10.1109/EEEIC.2012.6221488, 2012.
- [7] Ullah, Asad, Shahbaz Khan, and Sun Zhaoyun. "Power Factor Control Using Boost Type Converter." In 2018 IEEE 3rd Advanced Information Technology, Electronic and Automation Control Conference (IAEAC), pp. 54-60. IEEE, 2018.
- [8] H. Luo, J. Xu, D. He and J. Sha, "Pulse Train Control Strategy for CCM Boost PFC Converter With Improved Dynamic Response and Unity Power Factor," in IEEE Transactions on Industrial Electronics, vol. 67, no. 12, pp. 10377-10387, doi: 10.1109/TIE.2019.2962467, Dec 2020.
- [9] Kumar, P. Suresh, S. Sridhar, and T. Ravi Kumar. "Design & simulation of boost converter for power factor correction and THD reduction." Int. Jr. of ScientificEngg. & Tech. Res. IJSETR 3, no. 42: 8462-8466, 2014.
- [10] Musavi, Fariborz, Murray Edington, Wilson Eberle, and William G. Dunford. "Control loop design for a PFC boost converter with

ripple steering." *IEEE Transactions on Industry Applications* 49, no. 1: 118-126, 2012.

- [11] Chowdhury, Ahmed Sony Kamal, M. Shamir Shehab, M. Abdul Awal, and M. Abdur Razzak. "Design and implementation of a highly efficient pure sine-wave inverter for photovoltaic applications." In 2013 International Conference on Informatics, Electronics and Vision (ICIEV), pp. 1-6. IEEE, 2013.
- [12] Ramya, G.V. Ganapathy, and P. Suresh. "Comprehensive analysis of interleaved boost converter with simplified H-bridge multilevel inverter based static synchronous compensator system." *Electric Power Systems Research* 176: 105936, 2019.
- [13] V. Gurugubelli, and A. Ghosh, "Control of inverters in standalone and grid-connected microgrid using different control strategies," *World Journal of Engineering*, Jul. 2021.
- [14] Kim, Jaesik, Jaeho Choi, and H. Hong. "Output LC filter design of voltage source inverter considering the performance of the controller." In *PowerCon 2000. 2000 International Conference on Power System Technology. Proceedings (Cat. No. 00EX409)*, vol. 3, pp. 1659-1664. IEEE, 2000.
- [15] G. Vikash, A. Ghosh, "Parallel Inverters Control in Standalone Microgrid using different Droop Control Methodologies and Virtual Oscillator Control," *Journal of The Institution of Engineers (India): Series B*, pp.1-9, Jun. 2021.
- [16] R. Wai, C. Lin, Y. Huang and Y. Chang, "Design of High-Performance Stand-Alone and Grid-Connected Inverter for Distributed Generation Applications," in *IEEE Transactions on Industrial Electronics*, vol. 60, no. 4, pp. 1542-1555, doi: 10.1109/TIE.2012.2216232, April 2013.
- [17] G. Vikash, A. Ghosh, and S. Rudra, "Integration of Distributed Generation to Microgrid with Virtual Inertia," In 2020 IEEE 17th India Council International Conference (INDICON), Jul., 2020, pp. 1-6, IEEE.
- [18] Chowdhury, Ahmed Sony Kamal, M. Shamir Shehab, M. Abdul Awal, and M. Abdur Razzak. "Design and implementation of a highly efficient pure sine-wave inverter for photovoltaic applications." In 2013 International Conference on Informatics, Electronics and Vision (ICIEV), pp. 1-6. IEEE, 2013.
- [19] G. Vikash, D. Funde, and A. Ghosh, "Implementation of the Virtual Synchronous Machine in Grid-Connected and Stand-alone Mode," In *DC-DC Converters for Future Renewable Energy Systems*, Springer, Singapore., 2022, pp. 335-353.
- [20] Soomro, Jahangeer, Tayab, D. Memon, and M. A. Shah. "Design and analysis of single-phase voltage source inverter using Unipolar and Bipolar pulse width modulation techniques." In 2016 International Conference on Advances in Electrical, Electronic and Systems Engineering (ICAEES), pp. 277-282. IEEE, 2016.
- [21] V. Gurugubelli, A. Ghosh, and A. K. Panda, "Different Oscillator Controlled Parallel Three-Phase Inverters in Standalone Microgrid," In 1st International Symposium on Sustainable Energy and Technological Advancements (ISSETA 2021), Sep. 2021.
- [22] Alexa, Ioan-Alex, and Alexandru Onea. "Fast calculating PWM techniques of voltage source inverter." In 2014 18th International Conference on System Theory, Control and Computing (ICSTCC), pp. 526-531. IEEE, 2014.
- [23] V. Gurugubelli, A. Ghosh, A. K. Panda, and S. Rudra, "Implementation and comparison of droop control, virtual synchronous machine, and virtual oscillator control for parallel inverters in a standalone microgrid," *International Transactions on Electrical Energy Systems*, vol. 31, no. 5, e12859, May. 2021.
- [24] Kim, Hyosung, and Kyoung-Hwan Kim. "Filter design for grid-connected PV inverters." In 2008 IEEE International Conference on Sustainable Energy Technologies, pp. 1070-1075. IEEE, 2008.