

# VELOCITY AND REYNOLDS STRESS DISTRIBUTION IN STEADY OPEN CHANNEL FLOW

Firoj Shaik<sup>1</sup> Kishanjit Kumar Khatua<sup>2</sup>

<sup>1</sup>Civil Engineering Department, National Institute of Technology Rourkela, 769008, Odisha, India

<sup>2</sup>Civil Engineering Department, National Institute of Technology Rourkela, 769008, Odisha, India

Email: [firojshaik222@gmail.com](mailto:firojshaik222@gmail.com), [kkkhatua@yahoo.com](mailto:kkkhatua@yahoo.com)

## ABSTRACT

Measurements of mean velocities and Reynolds stress in steady open-channel flow were carried out over a smooth bed. Using Acoustic Doppler Velocimeter (ADV) and Constant Temperature Anemometry (CTA), the instantaneous velocities were obtained. In this study, both velocity and Reynolds stress profiles were analyzed. The effect of the instrument on these profiles were also examined by means of a comparison, over a longitudinal section of the channel. The flow patterns are investigated at five different lateral sections. The experimental data show that, both stream-wise velocity and Reynolds stress distribution deviated from the observed ADV results compared to CTA. In the regions of ( $z/H \leq 0.2$  and  $z/H > 0.7$ ), more variation in velocity. The Reynolds stress distribution from CTA at all measured sections was similar, which differentiate the measured ADV data.

**Keywords:** Steady flow, Smooth bed, CTA system, Micro-ADV

## 1. INTRODUCTION:

The study of open channel flow finds various applications in the field of engineering. An understanding of the hydraulic parameters is of importance in open channel flow. Considered the basic hydraulic parameter velocity, knowledge of turbulence characteristics is significant.

Because of the practical importance, immense experimental research has been performed on mean flow and turbulence structure. Open channel flow measurements have been carried out with different techniques, such as Prandtl tube, Acoustic Doppler velocity profiler (ADVP), Laser Doppler Anemometer (LDA), Propellers, Electromagnetic velocimeters, pitot tubes, Acoustic Doppler Velocimeter (ADV), Particle Image Velocimeters (PIV), etc.

Song et al. (1994) conducted experiments on a steep channel with movable gravel bed. Acoustic Doppler velocity profiler (ADVP) was used to obtain the information instantaneously on flow profiles in uniform flow condition. They studied the mean flow velocities, turbulence intensity distributions as well as Reynolds stress profiles with and without bed-load transport.

Kirkgoz (1989) used a laser Doppler anemometer (LDA) for velocity measurements in a fully developed subcritical open channel flow on smooth and rough beds. They presented a model for determining the reference bed level of the velocity distribution on rough surfaces and obtained the shear velocities from the measured velocity distribution profiles close to the bed.

Cardoso et al. (1989) worked on uniform flow in a smooth open channel. Mean velocities were found by Prandtl tubes for the selected two measuring stations. Finally, obtained the turbulence intensity profiles and shear velocity.

Nezu and Rodi (1986) carried out velocity measurements with a powerful two-color Laser Doppler Anemometer (LDA) system in a two-dimensional, fully-developed open channel flow over smooth

beds. The eddy viscosity, mixing length and turbulence intensities were obtained. The law of the wall and velocity defect law were re-examined.

Song and Chiew (2001) analyzed the turbulence structure in non-uniform open channel flow over a rough aluminum plate which was glued with sand particles. They considered a measuring section in which at five different sections velocity profiles were measured using acoustic Doppler velocimeter (ADV). They developed the theoretical expressions based on the Reynolds equation and continuity equation of 2D open channel flow for vertical velocity and Reynolds stress distribution.

Kironoto and Graf (1995) worked on turbulence characteristics in non-uniform flow condition. Prandtl tubes were used to measure the mean velocities over rough plate and gravel bed. Turbulence intensities and Reynolds stress profiles were analyzed.

Cardoso et al. (1991) experimentally investigated the steady gradually accelerating flow in a smooth open channel. They reported velocity and turbulence intensity profiles. They also presented influence of acceleration on bottom shear stress.

Yang et al. (2004) have developed a method for estimation of the Reynolds shear stress distribution and velocity dip phenomenon in smooth uniform open channel flow. The study proposes a dip-modified log law for the velocity distribution.

Meile et al. (2007) studied the improvement of Acoustic Doppler velocimetry by means of artificial seeding with the hydrogen bubble technique. They optimized the hydrogen bubble technique under steady and unsteady flow conditions. Further, Acoustic scattering level and properties of the seeding material were highlighted.

The objective of this study is a further contribution to our understanding of how velocity profiles and other flow parameters differ by changing the measuring instrument. This was done by using two different devices such as ADV and CTA.

## 2. THEORETICAL CONSIDERATION

### Basic equations

The variation of velocity with time at a given point denoted by  $u$ , the time average of the  $u$  component of velocity by  $\bar{u}$  and the difference between  $u$  and  $\bar{u}$  denoted by  $u'$ .

It is written as

$$u = \bar{u} + u' \quad v = \bar{v} + v' \quad w = \bar{w} + w' \quad (1)$$

Where  $u$ ,  $v$  and  $w$  are the instantaneous velocities in  $x$ ,  $y$ , and  $z$  directions respectively.

### Reynolds stress

Reynolds stresses can be defined as the time-averaged product of two components of the velocity.

$$-\overline{u'v'} = -\frac{1}{T} \int_0^T u'v' dt \quad (2)$$

Mathematically, an equilibrium flow is defined as

$$\frac{u}{U_d} = F(\eta) \quad (3)$$

$$\frac{\tau_{uv}}{\tau_0} = \frac{-\overline{u'v'}}{u_*^2} \quad (4)$$

Where  $u$  = stream-wise velocity;  $U_d$  = Depth-averaged velocity;  $u_*$  = Friction velocity;  $\tau_{uv}$  = Reynolds stress in  $xy$  plane;  $\tau_0$  = bed-shear stress;  $\eta = z/H$ ;  $U_d = \frac{1}{H} \int_{z=0}^H u dz$ ;  $H$  = water depth;

### Shear velocity

Shear velocity is a significant term in the context of computing the velocity profile as well as for determining the bed roughness.

$$u_* = \sqrt{gRS_0} \quad (5)$$

Where  $R$  = hydraulic radius of the channel at the measured section;  $S_0$  = bed slope

## 3. EXPERIMENTAL SETUP AND MEASURING EQUIPMENT

### 3.1 Experimental set-up

The experiments were conducted in a 5 m long, 30 cm wide, and 30 cm deep recirculating tilting flume in the Hydraulics Laboratory of Civil Engineering, National Institute of Technology Rourkela. The flume has made of mild steel. Fig. 1 shows the schematic diagram of an experimental setup and water recirculation system.

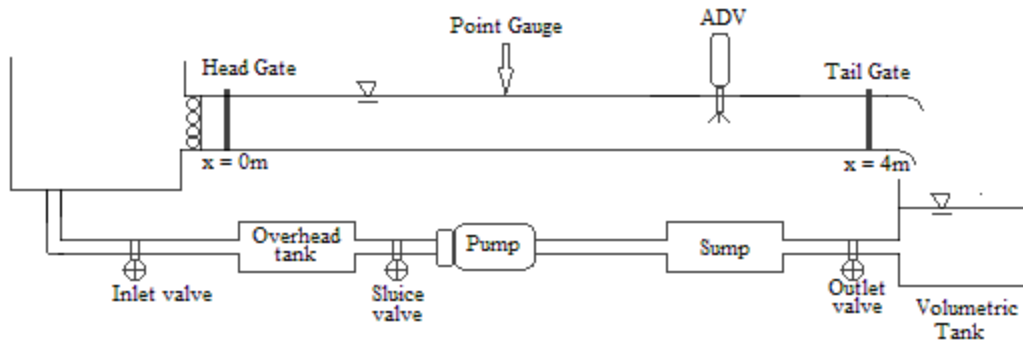

**Figure 1.** A Schematic view of the Flume and Water Recirculation system

A number of trial experiments were performed before conducting the final experiments in order to select the measuring section, in which flow was fully developed and to maintain the steady quasi-uniform flow in the measuring reach by tailgate operation. Several baffle walls and stabilizing devices exist in the inlet chamber which assures quasi-uniform entrance flow.

**Table 1:** Experimental channel description and parameters

Description	Parameter or value
Type of channel	Simple straight
Geometry of section	Rectangular
Nature of surface	Smooth steel bed
Flow condition	Steady
Length (L)	5m
Width of channel (b)	0.3m
Depth (d)	0.3m
Bed slope ( $S_0$ )	0.011

The flow was allowed to stabilize for about 1hr before starting the measurements, which are carried out at one single longitudinal section,  $x = 2.8$  m. For the selected longitudinal section, at an interval of 5 cm, measurements are conducted at five lateral sections as shown in Fig. 2, using. A point gauge is used to measure the depth of flow at the centerline of the flume. A bed slope ( $S_0$ ) of 0.00125 was set and kept unchanged throughout the experiments. The other details of channel and parameters are given in Table 1.

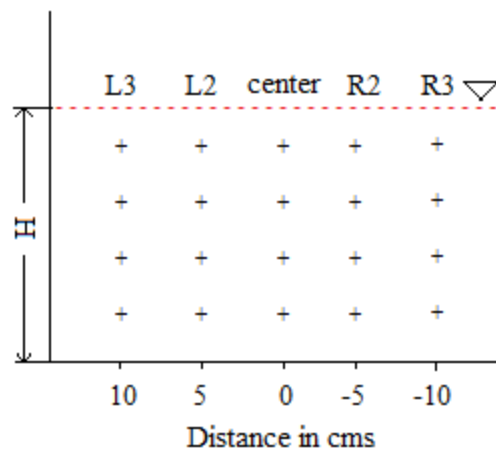
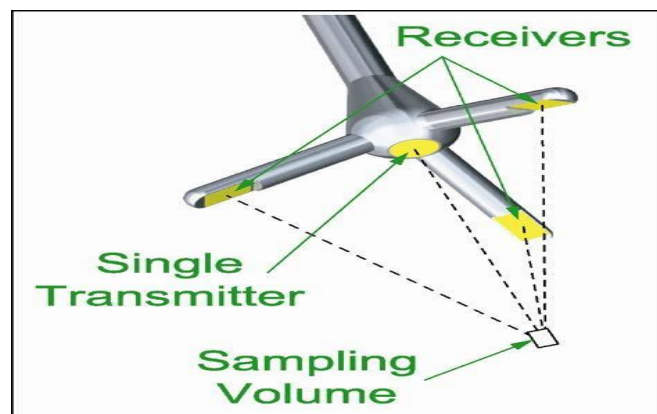

**Figure 2.** Velocity measurement grid

### 3. 2 Measuring instruments

#### 3.2.1 Acoustic Doppler Velocimeter (ADV)

An ADV measures 3-D flow velocities using the Doppler shift principle. The ADV operates on the pulse-coherent technique. The instrument consists of a sound transmitter, three sound receivers, and a signal conditioning module. The transmitter sends an acoustic signal that is reflected back by sound scattering particles present in the water, which are assumed to move at the velocity of water. The scattered sound signal is detected by the receivers and used to compute the Doppler shift, which is directly proportional to the velocity of the fluid. Micro-ADV offers the smallest sampling volume of  $0.09 \text{ cm}^3$ , which is at a distance of 5 cm from transmitter, as shown in Fig 3. ADV records three basic data types such as velocity, signal strength, and correlation coefficient scores. Signal strength is generally discussed in terms of signal to noise ratio (SNR), which is derived from signal amplitude by subtracting the ambient, background electronics noise level and converting into units of dB. correlation coefficient score is a direct measurement of ADV data quality which is expressed in percentage.



**Figure 3.** ADV probe configuration

The micro-ADV uses sound signals having a frequency of 16 MHz as a carrier frequency for data acquisition. It can read the instantaneous velocities with a maximum sampling rate of 50 Hz. The velocity measurements are carried out at five lateral sections such as  $L_3$ ,  $L_2$ , center,  $R_2$ , and  $R_3$  as shown in Fig 2. At each section, to complete the whole velocity profile, a down-looking, up-looking, and side-looking probe was used for measuring the velocity readings. For each measuring point, the data acquisition time is selected as 1 min, so that a total of 3000 instantaneous velocities were obtained for a 50 Hz sampling rate. The profiles were analyzed and compared with the CTA results.

### 3.2.2 Constant Temperature Anemometry (CTA)

CTA is a technique for the measurement of turbulence in gas and liquid flows, using hot-wire or hot-film probes placed in the flow. It is particularly suitable for flows with very fast fluctuations at a point and study of flow micro structures. The working principle is based on the cooling effect of a flow on a heated body.



**Figure 4.** CTA frame with controller and modules



**Figure 5.** Triaxial fiber film probe

The CTA can measure the velocities from a few cm/s to supersonic and fluctuations up to 400 KHz. CTA frame with controller and modules as shown in Fig 4. CTA anemometer works on the basis of convective heat transfer from a heated sensor to the surrounding fluid, the heat transfer is primarily related to the fluid velocity. The temperature of the sensor (Fig 5) is kept constant by an advanced feedback control loop that contains an electronic bridge circuit. In this way, the anemometer produces a continuous voltage that is proportional to the instantaneous flow velocity. The advantages of CTA are ease of use, the output is an analog voltage, which means that no information is lost.

#### Calibration

A calibration system is normally not considered part of the measuring chain. But it plays a significant role in CTA measurements for the accuracy and the speed, with which an experiment can be carried out. It can be done in a dedicated calibrator as shown in Fig 6. Calibration establishes a relation between the CTA output and the flow velocity. It is performed by exposing the probe to a set of known velocities,  $U$ , and then record the voltages,  $E$ . A curve fit through the points  $(E, U)$  represents the transfer function to be used when converting data records from voltages into velocities. The CTA signal is acquired via an analog to digital converter (A/D board) which is having a capacity of 100 KHz. A/D board helps in converting analog data into digital and saved as data series in computer.

#### Software

Stream Ware Pro is a dedicated software that helps to design and organize CTA measurements as well as post-process the results. It performs hardware set-up, automatic probe calibration, data acquisition, conversion, and reduction.

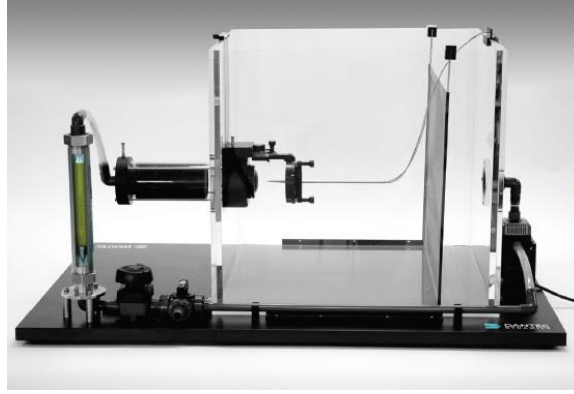

**Figure 6.** Water calibrator

The velocity measurements were conducted using CTA at the sections as shown in Fig 2. For collecting the data, a sampling frequency of 500 Hz and a total of 10000 samples were selected, so that it can measure the instantaneous velocities in 20 s.

## 4. RESULTS AND DISCUSSION

### 4.1 Stage-Discharge curve

The stage-discharge distribution in steady flow over a simple open channel is illustrated in Fig 7. The discharge is related to the stage as a logarithmic function. In this case, the curve follows a logarithmic profile. For a particular depth of flow ( $H = 9$  cm), the discharge goes on increasing with respect to stage.

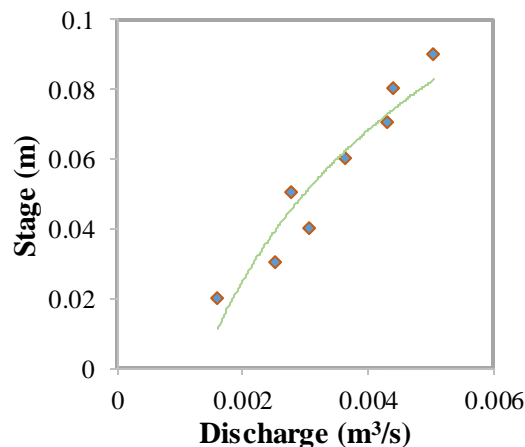
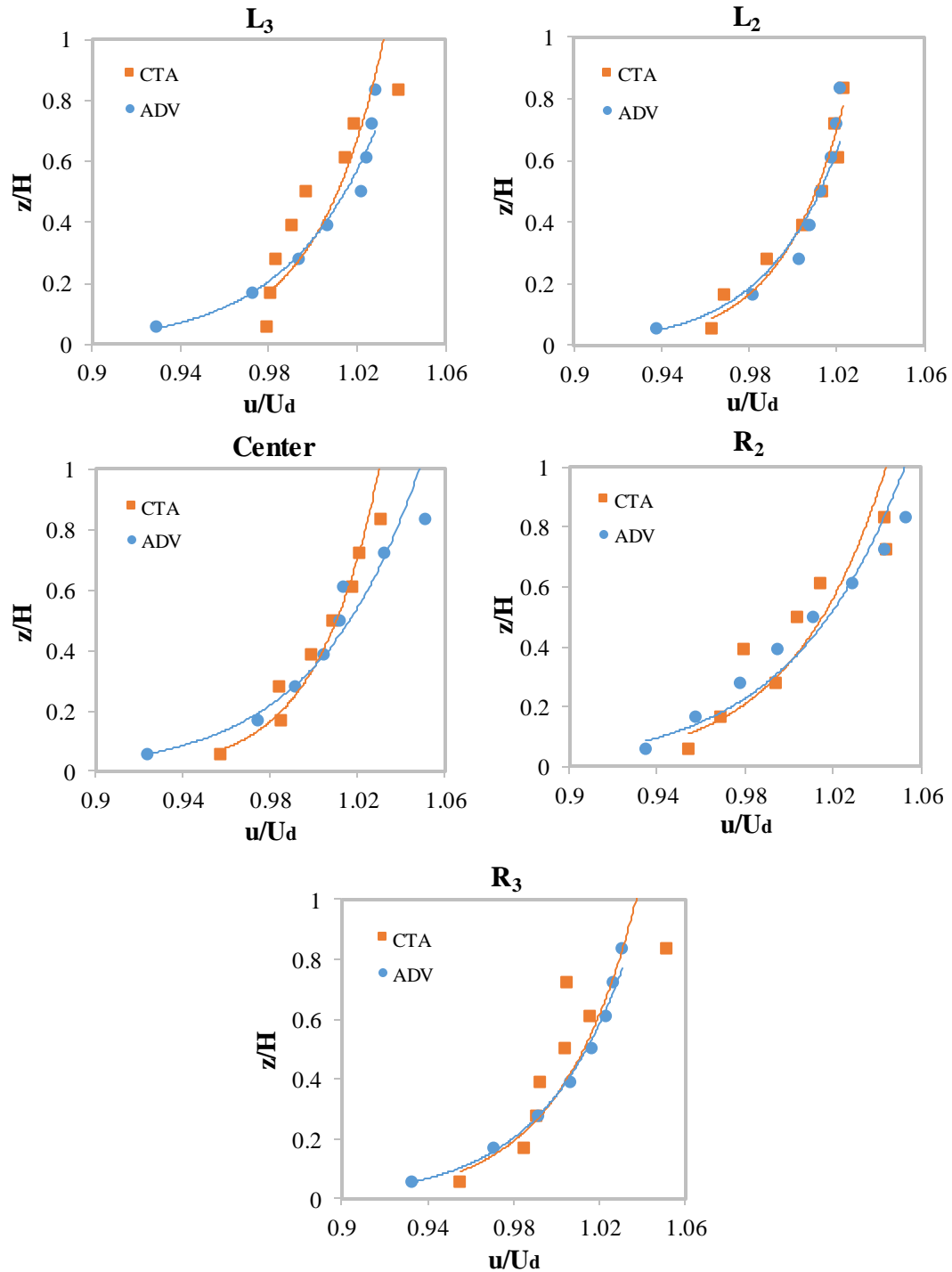

**Figure 7.** Stage-Discharge curve in a steady flow

### 4.2 Velocity Distribution

Velocity measurements were carried out to analyze the flow magnitude, the flow direction and to observe the comparison of velocity profiles on a smooth bed simple channel. For this purpose, The velocity observations were made at the specified grid positions for the selected longitudinal section as shown in Fig 2, which shows the lateral axis represented by lateral distance ( $y$ ). velocity profiles are observed from the centerline of the channel as origin at a lateral distance of 5 cm as shown in Fig 2. The distribution of stream-wise velocity as shown in Fig 8. In this, The velocity ( $u$ ) is normalized by depth-averaged velocity ( $U_d$ ), which is calculated by integrating the local point stream-wise velocities ( $u$ ) at that particular section. The vertical axis represents vertical distance ( $z$ ), which is normalized by

the depth of flow ( $H$ ). As seen in Fig 8, the velocity profiles tend to increase from bed of channel to near free surface at all measured sections. The stream-wise velocity determined by CTA and ADV showed higher difference in magnitude near to bottom surface of channel in all sections. It is clearly observed that, for center and  $R_3$  section, there is slightly more difference in velocity stated by CTA and ADV near to free surface, the same is also observed in central region of  $L_3$  section. In most of the regions, the velocity given by CTA is less compared to ADV. But when the fluid flows near to bottom surface of the channel, the CTA measured velocity is higher in comparison to ADV.



**Figure 8.** Distribution of normalized stream-wise velocity ( $u/U_d$ )

### 4.3 Reynolds Stress Distribution

In the results presented for Reynolds stress ( $-\overline{u'v'}$ ) which is normalized with  $u_*^2$  and the notations denoted in figures are  $\tau_{uv}$ ,  $\tau_0$  respectively. From Fig 9, it is observed that the Reynolds stress profile decreases from a near-bottom surface of the channel to free surface. It is clearly noticed that the Reynolds stress profiles plotted from CTA data was similar at all sections and the value is nearly zero. The Reynolds stress is higher at  $L_3$  and  $L_2$  compared to other sections which were determined by ADV and this observation is also stated the higher difference of Reynolds stress between CTA and ADV.

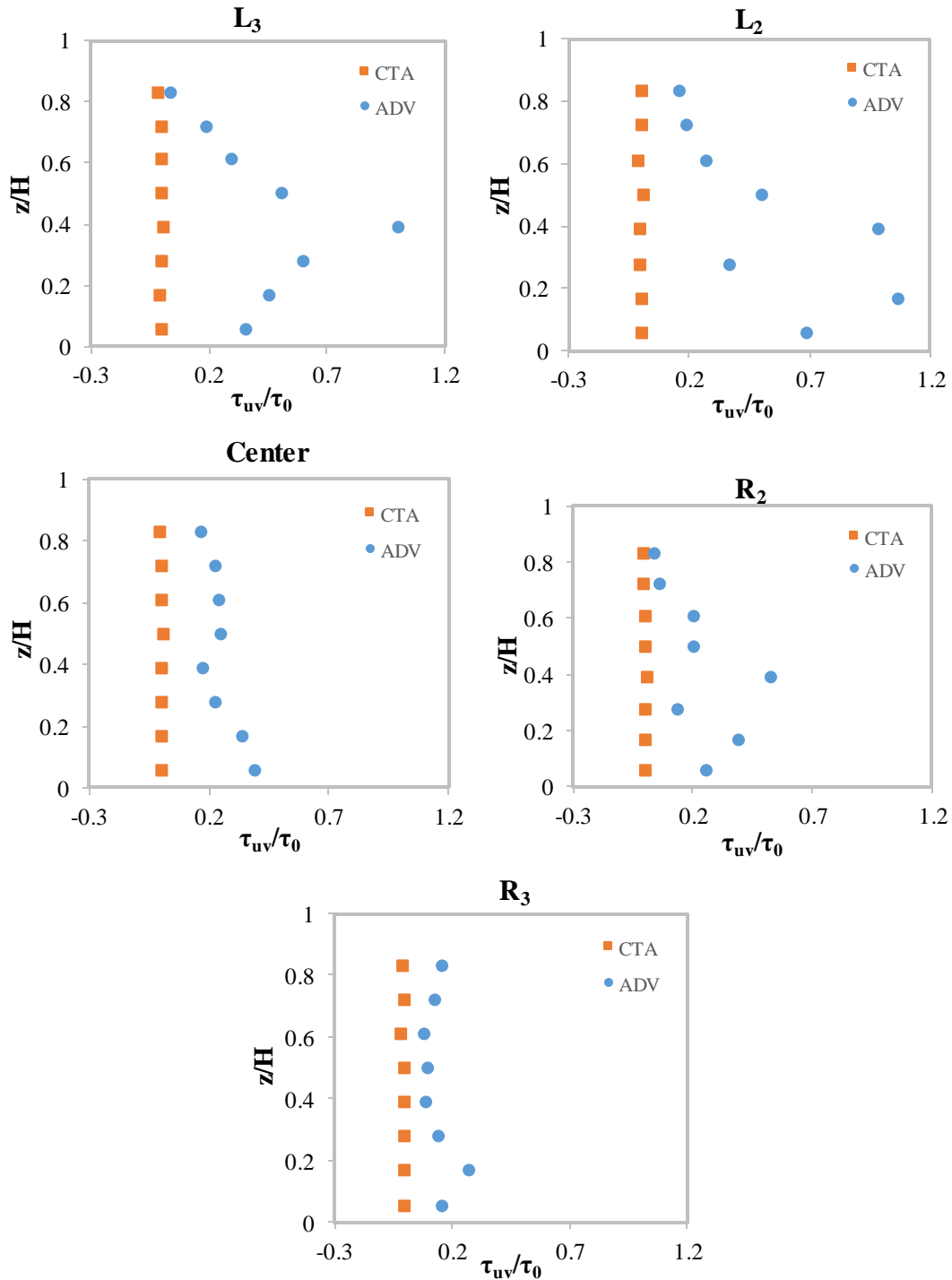

Figure 9. Normalized Reynolds stress distribution ( $\tau_{uv}/\tau_0$ )



## 5. CONCLUSIONS

Based on the experimental results of mean velocity and Reynolds stress distributions, it can be concluded that:

- The ADV has shown higher velocity compared to CTA in most of the region.
- It is observed that much difference in velocity profile at the center of the section when we compared ADV data with CTA particularly near the bottom surface.
- It is noticed that the velocity profiles were almost similar at  $L_2$  and  $R_3$  sections by both instruments.
- It is also revealed that reading more number of samples for determining the velocity can change the magnitude of Reynolds stress from the observation of similar distribution of Reynolds stress at all measured sections.
- In the central regions of  $L_3$  and  $L_2$ , Reynolds stress is higher from ADV and which is also deviated from the profile.

## REFERENCES

- Cardoso, A. H., Graf, W. H., & Gust, G. (1989). Uniform flow in a smooth open channel. *Journal of Hydraulic Research*, 27(5), 603-616.
- Cardoso, A. H., Graf, W. H., & Gust, G. (1991). Steady gradually accelerating flow in a smooth open channel. *Journal of hydraulic research*, 29(4), 525-543.
- Kirkgöz, M. S. (1989). Turbulent velocity profiles for smooth and rough open channel flow. *Journal of Hydraulic Engineering*, 115(11), 1543-1561.
- Kironoto, B. A., Graf, W. H., & REYNOLDS. (1995). Turbulence characteristics in rough non-uniform open-channel flow. *Proceedings of the institution of civil engineers-water maritime and energy*, 112(4), 336-348.
- Nezu, I., & Rodi, W. (1986). Open-channel flow measurements with a laser Doppler anemometer. *Journal of Hydraulic Engineering*, 112(5), 335-355.
- Song, T., & Chiew, Y. M. (2001). Turbulence measurement in nonuniform open-channel flow using acoustic Doppler velocimeter (ADV). *Journal of Engineering Mechanics*, 127(3), 219-232.
- Song, T., Graf, W. H., & Lemmin, U. (1994). Uniform flow in open channels with movable gravel bed. *Journal of Hydraulic Research*, 32(6), 861-876.
- Meile, T., De Cesare, G., Blanckaert, K., & Schleiss, A. J. (2008). Improvement of Acoustic Doppler Velocimetry in steady and unsteady turbulent open-channel flows by means of seeding with hydrogen bubbles. *Flow Measurement and Instrumentation*, 19(3-4), 215-221.
- Yang, S. Q., Tan, S. K., & Lim, S. Y. (2004). Velocity distribution and dip-phenomenon in smooth uniform open channel flows. *Journal of hydraulic engineering*, 130(12), 1179-1186.