

# Design of Portable Indicator for Underground Mines using 433 MHz Wireless Communication

Subhajit Indra

Department of Electronics and  
Communication Engineering,  
National Institute of Technology,  
Rourkela-769008, Odisha, India.  
Email: subhajit.indra@gmail.com

Sukumar Barik

Department of Electronics and  
Communication Engineering,  
National Institute of Technology,  
Rourkela-769008, Odisha, India.  
Email: sukumarbarik77@gmail.com

Umesh Chandra Pati

Department of Electronics and  
Communication Engineering,  
National Institute of Technology,  
Rourkela-769008, Odisha, India.  
Email: ucpati@nitrkl.ac.in

**Abstract**— The mining industry is the backbone of various manufacturing and infrastructure industries. In order to maintain a safe working environment, a lot of parameters need to be monitored periodically in underground mines. Wired indicators in underground mines incur a lot of regular maintenance. In wired network, if the wire gets broken then data from multiple sensors may get damaged. In wireless communication, the environment of a certain area can be analyzed at a distance. This paper proposes a portable wireless indicator, which can display the measurement of various critical parameters of underground mines. The parameters that have taken into consideration are temperature, pressure, and humidity. This indicator can communicate with multiple transmitters at a time using an efficient polling multiple access methods.

**Keywords**— Wireless RF communication, Mine Environment Monitoring, Polling Method, Multiple Access.

## I. INTRODUCTION

The environment in underground mines is harsh and inhospitable. Temperature and pressure readings are always on the higher side. As we move closer to the earth's crust, the temperature and pressure increase. Periodic measurement of temperature, pressure and humidity is necessary in order to assess the mining environment. Measurement of these parameters using conventional wired method is unreliable and requires periodic maintenance. A portable wireless indicator for measurement of these parameters is useful in the underground mines. Using this indicator, the operator can communicate with multiple transmitters much more efficiently.

There Wireless sensor networks are widely implemented in underground mines. In [1], a underground mobile wireless mobile sensor network (UMWSN) is proposed. This network uses Beacon-Based multi-hop routing (BBMHR) method when the transmitter is not in range with the receiver. In general, there are two most popular wireless communication channel used in underground mines: these are 433 MHz and 2.4 GHz frequency channel. ZigBee based communication system is one of the popular methods in 2.4 GHz frequency channel category for underground mines. Mohammad Ali et al. [2] have implemented one wireless sensor network based on ZigBee in underground mines. Multiple ZigBee modules have been used to cover a wide range in the underground mines. According to Qingyun Dai et al. [3], 433 MHz is having the higher range and also consumes low power. A wireless sensor network can also

be developed easily using this frequency channel. In order to check quality of the link length, B. Silva et al. [4] have experimentally analyzed that, 433 MHz is having lesser attenuation in underground soil than other higher frequency ranges.

According to Minhas et al. [5], in terms of Packet Error Rate and Received Signal Strength, 433 MHz is having better performance than the other higher frequency ranges in underground mines. A lot of work has been done in order to develop wireless sensor network in the underground mines. These methods explain how to transfer the data from underground to the control room situated at the ground level [6], [7]. According to Wang et al. [8], a combination of 2.4 GHz and 433 MHz can be used to configure a wireless sensor network. This network has been developed using Tree protocol. Sometimes a combination of ethernet and wireless sensor network has also been used as described by Hui Wang et al. in [9]. The efficiency of the Wireless Underground Sensor Network (WUSN) depends on the optimal node placement as described by Adamu et al. in [10]. A comparative analysis of wireless sensor performance of aboveground-to-underground and underground-to-aboveground has been shown in [11]. It can be observed that the soil performance is one of the key factors for Underground Wireless Sensor Network.

During landslide or damage of nodes in underground mines, the underground wireless sensor network may suffer significantly. This is due to change in concentration in the communication medium. A portable wireless indicator is useful to the operator to communicate with multiple transmitters and this does not suffer any problem related to network damage. In polling multiple access method [12], one receiver sequentially communicates with multiple transmitters. Using this efficient method, the proposed portable wireless indicator can find out the status of multiple transmitters easily.

This paper provides a design of a universal portable indicator, which can communicate with multiple transmitters. This indicator uses 433 MHz wireless communication channel as a communication medium. The indicator or receiver is made to communicate with three different transmitters of pressure, temperature and humidity. If the Identifiers (IDs) of the transmitters are known the operator can communicate with the transmitters easily.

This paper is organized as follows. Section II provides detailed design of proposed method. Section III discusses

experimental results obtained from the laboratory prototype model. Section IV concludes the paper.

## II. DESIGN OF PROPOSED METHOD

A schematic diagram of the proposed communication system for humidity and temperature transmitter is shown in Fig. 1. The schematic diagram of the proposed communication system for pressure transmitter is shown in Fig. 2. The schematic diagrams can be divided into three different parts such as (a) sensing unit, (b) transmitter and receiver unit and (c) multiple access method.

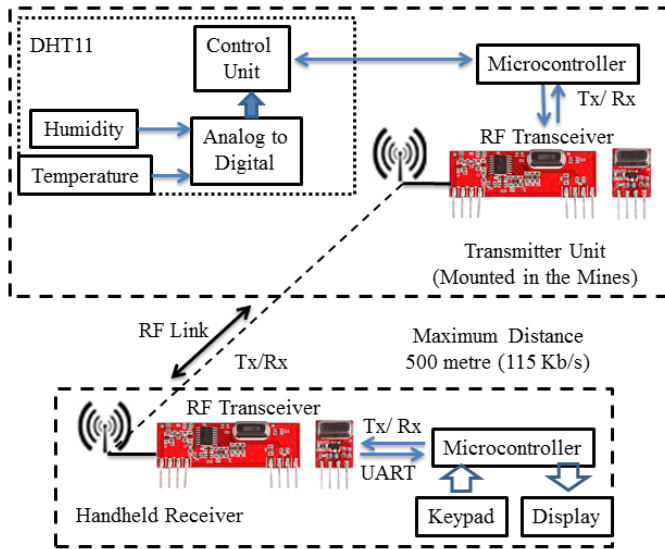

Fig. 1. Humidity and Temperature Transmitter Block Diagram

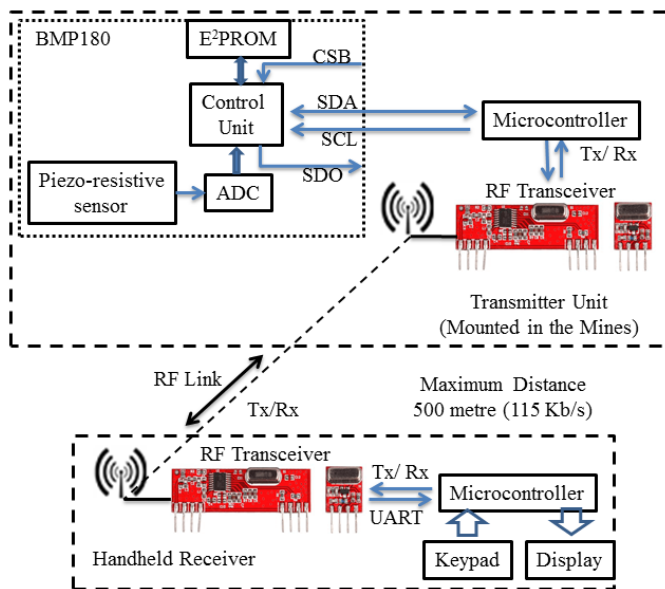

Fig. 2. Pressure Transmitter Block Diagram

Based on the block diagram, the hardware setup for transmitter units have been developed as shown in Fig. 3.

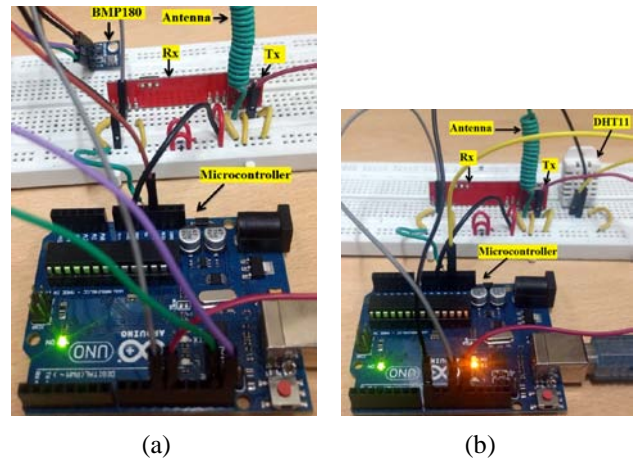

Fig. 3. (a) Pressure Transmitter Setup (b) Temperature/Humidity Transmitter setup

The pressure transmitter unit in Fig. 3 (a) uses BMP180 pressure sensor and the humidity transmitter unit in Fig. 3 (b) uses DHT22 humidity sensor. Similar to the humidity transmitter setup, one temperature transmitter setup has been developed using DHT22 sensor. All the transmitter units use a 433 MHz transmitter and receiver module, which constitute of single transceiver module.

### A. Sensing Unit

In order to communicate with multiple transmitters, in this work three parameters have been measured. The parameters are temperature, pressure and humidity. In order to measure temperature and humidity, two DHT22 sensors are used.

1) *Humidity and Temperature Sensor:* A humidity sensor senses the moisture content of the air in the environment. Relative humidity is an important factor, when the environment in mines is described. The ratio of moisture contain in air to the maximum amount of moisture at a particular air temperature is called relative humidity. For measuring the humidity and temperature, a DHT22 humidity sensor has been used. The temperature sensor in DHT22 is a negative temperature coefficient type thermistor. For humidity, a polymer capacitor is used as sensing element. It has four pins. Pin-1 is connected with supply voltage, pin-2 is the output data pin, pin-3 is not connected with anything and pin-4 is connected with ground. The sensor senses the humidity as well as temperature and gives the output in the form of digital data. The operating range of the sensor is 0 - 100 % RH and - 400° Celsius to 800 ° Celsius. The sensor has an accuracy of  $\pm 2$  % RH and 0.5 ° Celsius for humidity and temperature respectively. Resolution for the sensor is 0.1 % RH for humidity and 0.1 ° Celsius for temperature. The actual DHT22 humidity sensor is shown in Fig. 4.



Fig. 4. Humidity and Temperature Sensor

1) *Humidity and Temperature Sensor:* A pressure sensor senses the surrounding atmospheric pressure inside the mines. BMP180 pressure sensor can sense the pressure from 300 hectopascal to 1100 hectopascal (+9000 metre to -500 metre relative to sea level). It is having a low altitude noise of 0.25 metre at conversion time. It is based on piezo-resistive technology. Due to the atmospheric pressure the electrical resistance of the sensor varies and that change in resistance is calibrated in terms of pressure. It communicates with the microcontroller via I<sup>2</sup>C interface bus. Fig. 5 shows the actual sensor.

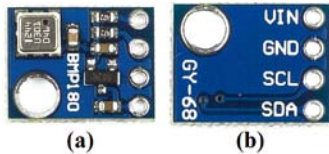

Fig. 5. Pressure Sensor (a) Top View (b) Bottom View

### B. Transmitter and Receiver Unit

Data from each sensor is taken using ATMEGA328 microcontroller. It is having 32 Kb memory and 10-bit internal Analog to Digital Converter. In order to reduce power consumption, the microcontroller in both the transmitter and receiver units use MCP1702 CMOS low dropout 5 Volt voltage regulator. The microcontroller takes direct digital data from the humidity and temperature transmitter. However, in order to take the data from pressure sensor, it uses I<sup>2</sup>C interface bus. It is a serial protocol used to communicate with peripheral devices having slower speed. One 433 MHz transmitter and receiver module is connected to the microcontroller. These modules use Amplitude Shift Keying (ASK) method for communication. The transmitter and receiver module together constitute a single transceiver module. Whenever a request command is received from the receiver unit, the transmitter then reads the data from the sensor and sends it to the receiver. While communicating using 433 MHz modules, each data packet consists of training bits, start symbol, message byte count, message byte and frame check sequence.

In a similar manner, the portable wireless indicator or the receiver unit is also equipped with a 433 MHz transmitter and receiver module. The receiver is having one keyboard as well as one liquid crystal display (LCD). Using polling multiple access methods, the receiver broadcasts the duration and IDs one by one and displays the measured data in the LCD. The data that is displayed in the LCD contains the ID and the measurement value with unit.

### C. Multiple Access Method

The operator at a time may come across more than one sensor in the underground mine. If the operator starts communicating with each transmitter one by one, then the process becomes time-consuming and difficult. If a multiple access method is incorporated here, then the operator can communicate with transmitters more efficiently. There are various multiple access methods that are widely used in the

industry. The methods can be divided into two categories - the one with data conflicts and the one which is free of any data conflicts. Conflict Free multiple access methods are Polling, Token Passing, Time Division Multiple Access, Frequency Division Multiple Access and Code Division Multiple Access. The method having the chance of data conflicts are ALOHA, Carrier Sense Multiple Access and Binary Tree. Out of these methods, Polling is the only method where the data communication sequence can be predicted accurately. In polling method, the operator provides a list of IDs to the receiver and the receiver communicates with each ID sequentially. Using this efficient method, the operator can access all the transmitters within range accurately. The communication algorithms of transmitter and receiver units are shown in Fig. 6 and 7.

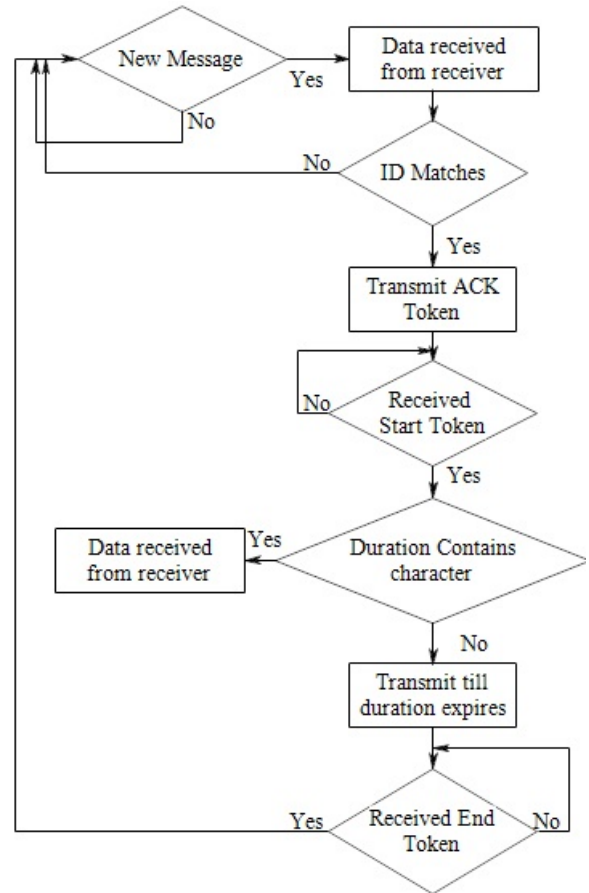

Fig. 6. Transmitter Algorithm

At first, the number of transmitters, their respective IDs and duration of communication are fetched in the receiver. The receiver then broadcast a message containing the duration and first ID. If the acknowledge message is not received till 5 seconds, then the receiver shows that the transmitter is not in range and transmit the details to the next ID. If acknowledge message from the transmitter received by the receiver, then receiver checks with sent ID. If the ID matches, then it sends START token to the transmitter. If there is any ID mismatch, then the receiver waits for another acknowledgment message. After sending the START token, the receiver displays the

received message till timeout. After that, it sends END token to complete the communication and moves on to the next transmitter. This goes on till the number of transmitters becomes zero.

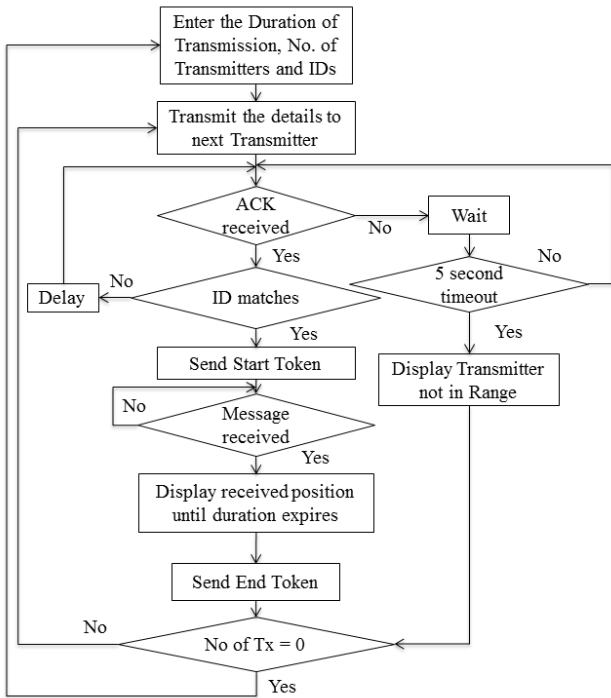

Fig. 7. Receiver Algorithm

In case of transmitter, it always checks for new message. If the data received at the receiver and the ID matches, then it transmits the acknowledgment token containing its address to the receiver. After receiving the START token, the transmitter transmits the data till the time is exhausted and then it waits for the END token. It again waits for new message after receiving the END token. If there is any character (\*) in the time duration, then it transmits the data till an indefinite period. The data packet consists of a sensor value and ID. The transmitter is having a range up to 30 m without any line of sight in above ground. Underground communication depends on the volume of water content in the soil

### III. EXPERIMENTAL RESULTS

#### A. Transmitter in Range

As shown in the Fig. 3, the prototype pressure, humidity and temperature transmitters have been developed. In order to measure the temperature, DHT22 sensor has been used with a similar setup of humidity transmitter. The IDs of the temperature, pressure and humidity transmitters are 2900, 3000 and 3100 respectively. The experiment is conducted in the laboratory environment.

In the receiver, first the duration of the transmission has been given as 10 seconds. Then, the number of transmitters has been selected as 3. Then the IDs of each transmitter are entered as follows - 3100, 2900, and 3000. The receiver unit then broadcasts a request message containing ID of the first transmitter and duration of communication to the medium.

In this experiment, the receiver first communicates with the humidity transmitter (3100) and displays the humidity for 10 seconds. Then it communicates with temperature transmitter (2900) and after that it goes on to communicate with pressure transmitter (3000) for 10 seconds. The communication is done sequentially and accurately without any data conflicts. The displayed results of the receiver are shown in Fig. 8. The display shows the parameter values with corresponding unit and the ID of the transmitter from which it received the message.

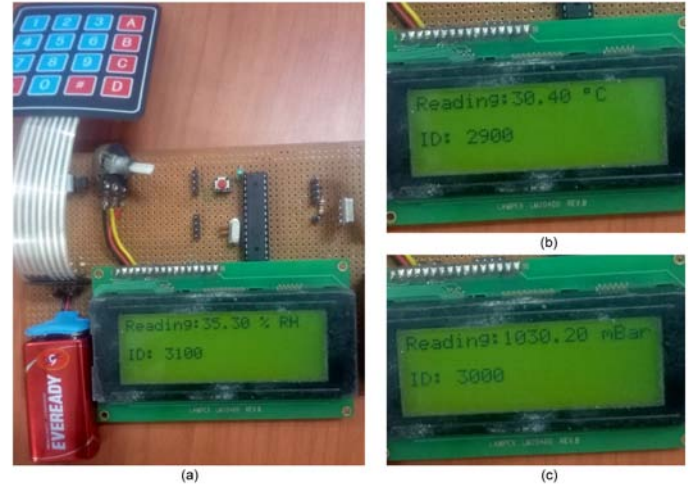

Fig. 8. (a) Data from Humidity Sensor (b) Data from Temperature Sensor (c) Data from Pressure Sensor

#### B. Transmitter not in Range

Using 433 MHz frequency channel the operator can communicate with all the transmitters up to 500 metre. The operator can also communicate with transmitters up to 30 metre without any line of sight. In the mines, there are chances that the transmitters may not be in range of the receiver. If this situation occurs, the receiver waits for acknowledgment from the transmitter for 5 seconds after sending the request data packet. If the receiver does not receive the response within the stipulated time, the display shows that the transmitter is not in range. This message is very useful for the mining personnel whenever they want to know the status of the surrounding area.

### IV. CONCLUSION

This paper provides the design details of a portable wireless indicator for underground mines. This indicator has been developed using polling multiple access methods and it can communicate with multiple transmitters sequentially and without any data conflicts. The receiver displays the data of multiple transmitters with the ID of those transmitters. For any wireless network, if there is any node breakage, the overall communication may suffer. Using this portable device, the operating personnel can communicate with multiple transmitters as per his choice. It is easier for the operator to measure the data in the surrounding area. This method can be applied for the measurement of not only pressure, temperature

and humidity but also other critical parameters. In future, this can be incorporated in an existing wireless network.

#### REFERENCES

- [1] G. Qiao and J. Zeng, "An underground mobile wireless sensor network routing protocol for coal mine environment," *Journal of Computational Information Systems*, vol. 7, no. 7, pp. 2487–2495, 2011.
- [2] M. A. Moridi, M. Sharifzadeh, Y. Kawamura, and H. D. Jang, "Development of wireless sensor networks for underground communication and monitoring systems (the cases of underground mine environments)," *Tunnelling and Underground Space Technology*, vol. 73, pp. 127 – 138, 2018.
- [3] Q. Dai, Y. Liu, Z. Jiang, Z. Liu, K. Zhou, and J. Wang, "Mes wireless communication networking technology based on 433mhz," in *2008 2nd International Conference on Anti-counterfeiting, Security and Identification*, Aug 2008, pp. 110–113.
- [4] B. Silva, R. M. Fisher, A. Kumar and G. P. Hancke, "Experimental Link Quality Characterization of Wireless Sensor Networks for Underground Monitoring," in *IEEE Transactions on Industrial Informatics*, vol. 11, no. 5, pp. 1099-1110, Oct. 2015.
- [5] U. I. Minhas, I. H. Naqvi, S. Qaisar, K. Ali, S. Shahid and M. A. Aslam, "A WSN for Monitoring and Event Reporting in Underground Mine Environments," in *IEEE Systems Journal*, vol. 12, no. 1, pp. 485-496, March 2018.
- [6] M. A. Akkaş, "Using wireless underground sensor networks for mine and miner safety," *Wireless Networks*, vol. 24, no. 1, pp. 17–26, Jan 2018.
- [7] Y. S. Dohare, T. Maity, P. S. Paul and H. Prasad, "Smart low power wireless sensor network for underground mine environment monitoring," *2016 3rd International Conference on Recent Advances in Information Technology (RAIT)*, Dhanbad, 2016, pp. 112-116.
- [8] Q. f. Wang, S. Zhang, Y. Yang and L. Tang, "The application of wireless sensor networks in coal mine," *2009 7th International Conference on Information, Communications and Signal Processing (ICICS)*, Macau, 2009, pp. 1-4.
- [9] H. Wang, F. Luo, K. Wang, and Y. Xu, "An emergency communication architecture based on ethernet and wsn for coal mines," *Procedia Engineering*, vol. 23, no. 1, pp. 403 – 407, 2011.
- [10] A. M. Zungeru, M. Mangwala, and J. Chuma, "Optimal node placement in wireless underground sensor networks," *International Journal of Applied Engineering Research*, vol. 12, no. 20, pp. 9290–9297, 2017.
- [11] X. Yu, P. Wu, N. Wang, W. Han, and Z. Zhang, "Development of a new wireless sensor network communication." *Journal of Computers*, vol. 8, no. 10, pp. 2455–2460, 2013.
- [12] F. Tobagi and L. Kleinrock, "Packet Switching in Radio Channels: Part III - Polling and (Dynamic) Split-Channel Reservation Multiple Access," in *IEEE Transactions on Communications*, vol. 24, no. 8, pp. 832-845, August 1976.