

# Modelling GPR for Characterization of Subsurface EM Properties

Subrata Maiti<sup>1</sup>, Prof. Sarat K. Patra<sup>1</sup>, Prof. Amitabha Bhattacharya<sup>2</sup>

<sup>1</sup>Department of Electronics and Communication Engineering, NIT Rourkela, Odisha, India

<sup>2</sup>Department of Electronics and Electrical Communication Engineering, IIT Kharagpur, West Bengal, India

**Abstract**—The full waveform modelling of Ground Penetrating Radar (GPR) signal is a promising approach to implement GPR system. The complexity of inverting this model is very high. With suitable optimization scheme, it is possible to invert the model with reasonable efficiency and accuracy. This paper implements a full wave inversion method with Genetic Algorithm (GA) based optimization scheme to extract the model parameters. The performance of this model is compared with the surface reflection method and a Time Domain Reflectometry (TDR) scheme.

**Keywords**— Ground penetrating radar (GPR), inverse modelling, SFCW radar, soil dielectric properties.

## I. INTRODUCTION

GPR has gained considerable research interest in recent years due to its potential to apply it for variety of civilian and military applications [1,2]. The complexity of GPR attributes to high attenuation of electromagnetic (EM) wave in ground coupled with stochastic behaviour of the ground subsurface. The problem becomes more complex due to similarities of EM properties of different objects under GPR environment. The accuracy of GPR signal modelling is an important requirement to retrieve the ground sub-surface properties by suitable inversion scheme. Classically different analytical and numerical techniques [2] have been used for modelling GPR signal. The Common Midpoint (CMP) method [3], which is based on the wave propagation speed is a popular approach used for the GPR signal analysis. But it is a time consuming method as it requires several traces for single profile measurement. The surface reflection method [4] is generally applied for large scale mapping of subsurface properties. However, this method yields low resolution with high uncertainty in absence of a clear reflecting layer in the ground [5]. Lambot [6] has proposed a full wave forward and inverse modelling to realize an off-ground monostatic Stepped Frequency Continuous Wave (SFCW) GPR. In this method the air-subsurface is modelled as Green's function based on the solution of 3-D Maxwell's equation for the signal propagation in multi-layered media. The Global Multilevel Coordinate Search (GMCS) along with Nelder-Mead Simplex algorithm (NMS) is applied to invert the model.

In this study an SFCW GPR is implemented in the laboratory using full wave inversion method based on hybrid GA optimization and the surface reflection method to model the GPR signal. The results of the schemes are compared with a simulated Time Domain Reflectometry (TDR) scheme.

## II. GPR SIGNAL MODELLING

### A. GPR System

The SFCW radar is implemented with the help of a network analyser (NA: E5071C of Agilent) and a single TEM horn antenna. Here the antenna is kept at a certain height above the ground (Figure 3) so that the measurement can be done at the far field of the antenna. This simplifies the problem as the antenna can be modelled as single point source and receiver. Secondly, as the received signal at the antenna has travelled in vertical direction, the stochastic variation of the ground surface has little effect on the received signal strength. The ground can be modelled as horizontally multilayered geometry, whose closed form response function can be derived by solving the Maxwell's equations. Further, the monostatic mode of operation simplifies the solution of Maxwell's equation as the oscillating Bessel function of Sommerfield integral evaluation vanishes.

### B. Surface Reflection Method

The following assumptions are important for the surface reflection coefficient method: (1) The antenna is located off the ground and the target is in the far field. (2) The soil electric conductivity is negligible and relative permeability is 1. (3) The antenna distortion effects are negligible.

The relative dielectric permittivity  $\epsilon_r$  can be evaluated based on the Fresnel's reflection coefficients  $R$  of the soil surface with the following relations.

$$\epsilon_r = \left(\frac{1-R}{1+R}\right)^2 \quad (1)$$

The reflection coefficient  $R$  is the ratio between the reflected wave and the incident wave for the normal incidence of the plane wave. For GPR application it is usually measured by the relative amplitudes of the reflected signal from ground target and a PEC (Perfect Electric Conductor) at a same distance as given by the formula mentioned below.

$$R = -\frac{E_r}{E_{r,PEC}} \quad (2)$$

Where  $E_r$  is the reflected electric field due to actual target and  $E_{r,PEC}$  is the reflected field due to PEC at same distance from the GPR antenna.

### C. Full Wave inversion method

#### 1) VNA-Antenna-ground subsurface modelling:

The monostatic UWB SFCW GPR uses Vector Network Analyzer (VNA) for the measurement. The GPR signal is modelled based on the complex reflection coefficient  $S_{11}(\omega)$  measurement at the VNA port. The VNA, antenna and

subsurface are modelled as linear systems in series and parallel as given below.

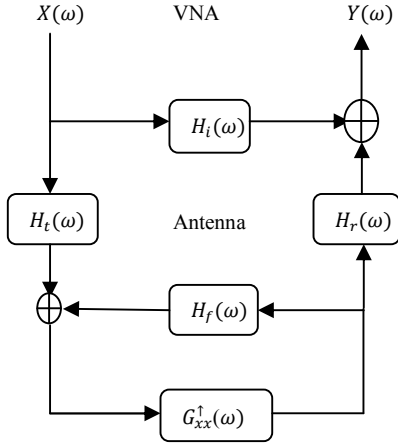

Figure 1: Block diagram representing the VNA-antenna-multilayered medium system [6].

By applying Masson's gain formula we get

$$S_{11}(\omega) = \frac{Y(\omega)}{X(\omega)} = H_i(\omega) + \frac{H_t(\omega)G_{xx}^\dagger(\omega)H_r(\omega)}{1-H_f(\omega)G_{xx}^\dagger(\omega)} \quad (3)$$

where  $X(\omega)$  is the transmitted signal and  $Y(\omega)$  is the received signal at the VNA reference plane;  $H_i(\omega)$  is the return loss of the antenna,  $H_t(\omega)$  is the transmit transfer function of the antenna,  $H_r(\omega)$  is the receive transfer function of the antenna, and  $H_f(\omega)$  represents the feedback loss transfer function.  $G_{xx}^\dagger(\omega)$  is the transfer function representing the air-subsurface systems. This is also called as Green's function of the air-sub-surface system. All these reflection and transfer functions can be measured by the calibration testing process on known model configurations of ground. In this case the measurements are taken with antenna placed at different heights on a metal sheet.

### 2) Electromagnetic(EM) properties of the materials:

The propagation of the EM wave is guided by the Maxwell equations. There are direct relations between the reflected scattered field and the EM properties of the subsurface ground layers. Most of the materials encountered in the earth surface are non-magnetic in nature. Therefore the earth's sub-surface materials and man-made objects are mostly classified based on the conductivity ( $\sigma$ ) and dielectric constant ( $\epsilon$ ) profile.

The conduction current density,  $J_c$  and the displacement current density,  $J_d$  are expressed by Ohm's law as

$$J_c = \sigma E \text{ and } J_d = j\omega\epsilon E.$$

The electric conductivity ( $\sigma$ ) and dielectric constant ( $\epsilon$ ) can be expressed as complex quantity as following.

$$\sigma = \sigma' + j\sigma'' \text{ and } \epsilon = \epsilon' - j\epsilon''.$$

The total current density is therefore equal to

$$J = J_c + J_d = j\omega\epsilon_e E \quad (4)$$

$$\text{where } j\omega\epsilon_e = \sigma + j\omega\epsilon = (\sigma' + \omega\epsilon'') + j(\sigma'' + \omega\epsilon') \quad (5)$$

$\epsilon_e$  is called the effective dielectric constant.

It is well established that the soil materials have significant dispersive property over the wide band GPR operating range. The real part of the  $\epsilon_e$  is not a strong function of the frequency [6]. Whereas the complex part can be assumed to be a linear function of the frequency over the limited operating frequency region (0.8 GHz to 2.0 GHz). The apparent conductivity  $\sigma = (\sigma' + \omega\epsilon'')$  in Equation 5 can be expressed as following.

$$\sigma(f) = \sigma_0 + \alpha(f - 0.8 \times 10^9) \quad (6)$$

where  $\sigma_0$  is the static electric conductivity at 0.8 GHz and  $\alpha$  is the linear variation rate.

### 3) Modelling air-subsurface with Green's function:

Here the air-ground surface is modelled as an N horizontal layered medium separated by N-1 interfaces as illustrated in the Figure 2. Any single nth layer is homogeneous and is characterized by permittivity ( $\epsilon_n$ ), conductivity ( $\sigma_n$ ) and thickness ( $h_n$ ). The permeability ( $\mu_n$ ) is assumed to be free space value ( $\mu_0$ ). The Green's function ( $G_{xx}^\dagger$ ) here is the solution of Maxwell's equation for the multilayered media for the unit source. This is well known and discussed in various literatures [7], [8]. The source and receiver point is located at the upper half space, at the origin O of the coordinate system. The radiating part of the horn antenna is assumed to be an infinitesimal horizontal x-directed electric dipole (second subscript in  $G_{xx}^\dagger$ ) and the receiving part of the antenna is denoted by measuring the horizontal x-directed part (first subscript in  $G_{xx}^\dagger$ ) of the backscattered electric field (up arrow in  $G_{xx}^\dagger$ ). The effect of the soil roughness is neglected according to the Rayleigh criterion.

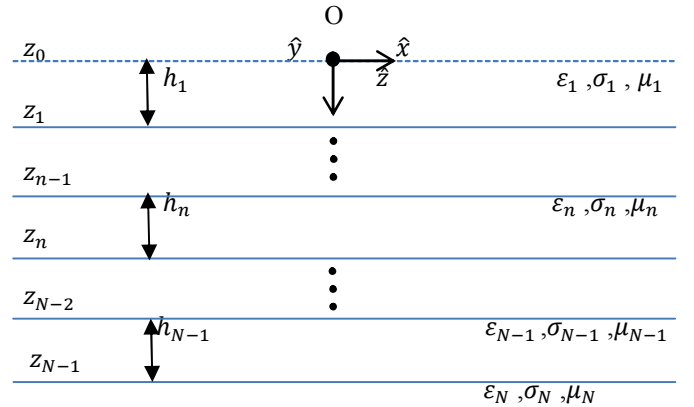

Figure 2: Model configuration of N-layered medium with a point source.

Now following the approach of Lambot et al. [6] the spatial domain Green's function at the source point  $((x, y, z) = 0)$  is obtained from the spectral domain Green's function as

$$G_{xx}^\dagger(0, \omega) = \frac{1}{4\pi} \int_0^{+\infty} \tilde{G}_{xx}^\dagger(k_\rho, \omega) dk_\rho \quad (7)$$

The integration variable  $k_\rho$  is a spectral parameter. The analytical expression of the Green's function in the spectral domain can be derived and its final form is given below.

$$\tilde{G}_{xx}^\uparrow(k_\rho, \omega) = \left[ R_n^{TM} \frac{\Gamma_n}{\eta_n} - R_n^{TE} \frac{\xi_n}{\Gamma_n} \right] e^{-2\Gamma_n h_n} \quad (8)$$

where  $n=1$  for single layered ground media,  $R_n^{TM}$  is the transverse magnetic global reflection coefficient and  $R_n^{TE}$  is the transverse electric global reflection coefficient accounting for all reflections from the multilayered interfaces.  $\Gamma_n$  is the vertical wave number of the  $n$ -th layer defined as  $\Gamma_n = \sqrt{k_\rho^2 + \xi_n \eta_n}$ ,  $\xi_n = i\omega\mu_n$ , and  $\eta_n = \sigma_n + i\omega\epsilon_n (= j\omega\epsilon_{e,n})$ .

#### 4) Model inversion:

The estimation of subsurface material parameters by the inversion of forward modelling is a non-linear problem. We need to find out the vector  $\mathbf{b}=[\epsilon_n, \sigma_n, h_n]$  of parameters so that the objective function  $\Phi(\mathbf{b})$  in Equation 9 is minimized. If observation errors are independent zero mean stationary Gaussian process and there is no prior information on parameters, the maximum likelihood approach reduces to the weighted least-squares problem. Therefore the objective function can be defined as following.

$$\Phi(\mathbf{b}) = |G_{xx}^{\uparrow*}(\omega) - G_{xx}^\uparrow(\omega, \mathbf{b})|^T \frac{1}{\sigma^2} |G_{xx}^{\uparrow*}(\omega) - G_{xx}^\uparrow(\omega, \mathbf{b})| \quad (9)$$

where  $G_{xx}^{\uparrow*}(\omega)$  are the vectors containing measured and  $G_{xx}^\uparrow(\omega, \mathbf{b})$  are the vectors containing simulated response function of the multilayered medium, and  $\sigma^2$  is the error variance. The objective function ( $\Phi(\mathbf{b})$ ) is highly non-linear and has got multiple minima over the multi dimensional parameter vector space. Here a GA based hybrid algorithm is implemented in Matlab to estimate the soil parameters. The number of parameters need to be optimized for a single layered ground media are five i.e. height of the antenna from the sand surface ( $h_0$ ), sand layer thickness ( $h_1$ ), relative dielectric constant ( $\epsilon_{r1}$ ), static conductivity ( $\sigma_{01}$ ) and conductivity variation coefficient ( $\alpha$ ). The efficiency of GA based technique depends on defining initial parameter vector and its range of variation. Here the initial values of parameters are calculated based on GPR processing by the surface reflection coefficient method.

### III. EXPERIMENTAL SETUP

The radar measurements were conducted on a roof top with the antenna on top of a wooden tank (138.5×98.5 cm) and a steel plate (122×81 cm) at the bottom of the tank (Figure 3). The dimension of the antenna (BBHA 9120A, Schwarzbeck Mess-Elektronik) is 24.5×22×14.2 cm. The operating frequency band of the antenna is from 800 MHz to 5 GHz. But the frequency range of 800 MHz to 2000 MHz is used with a frequency step of 10 MHz to process the highest quality data. The metal plate is used to control the boundary condition for the radar measurement as well as to calibrate the radar system. Due to manual adjustment of the antenna stand, our height measurement inaccuracy was around 1 cm.



Figure 3: Picture of the GPR setup at roof top.

### IV. RESULTS AND DISCUSSION

#### 1) Estimation of the wet sand parameters:

After the calibration, GPR measurement was conducted with wet sand kept in the wooden box on top of the metal sheet. Following this, simulation was conducted in a 2.13 GHz, Intel core i3 CPU laptop to estimate the soil's electrical parameters. It took around 9s for the surface reflection method and 290s for the full wave inversion method to estimate the soil parameters. The results are presented in the TABLE 1.

TABLE 1: SOIL PARAMETERS EXTRACTED BY DIFFERENT METHODS

| Measurement Methods | EM Parameter types |             |                 |                       |                     |
|---------------------|--------------------|-------------|-----------------|-----------------------|---------------------|
|                     | $h_0$ (c m)        | $h_1$ (c m) | $\epsilon_{r1}$ | $\sigma_{01}$ (m S/m) | $\alpha$ (mS/m/GHz) |
| Manual measurement  | 24.8               | 7.5         | -               | -                     | -                   |
| Simulated TDR       | i/p                | i/p         | 5.51            | -                     | -                   |
| Surface reflection  | 24.95              | 7.55        | 5.44            | -                     | -                   |
| Full wave inversion | 24.70              | 7.52        | 5.54            | 19.83                 | 11.57               |

Here the simulated TDR scheme is implemented based on the propagation delay of EM wave travelling through the media. This method is expected to give correct value of dielectric constant while conductivity of the sub-surface media is negligible. The Figure 4 presents plot of the measured and the modelled Green's function for the single layered wet sand in frequency and time domain. It shows partial agreement between the measured and the modelled Green's functions. The reflections from the sand surface as well as from the metal plate are clearly visible.

#### 2) Detection of water layer:

Then experiment was conducted for detecting a water layer of 3.5 cm thickness. The measurement result is presented in the TABLE 2. It is observed that accuracy of the full wave inversion scheme is better than the surface reflection method. The reflections from the water surface and the metal plate are clearly visible in the time domain plot presented in Figure 5.

TABLE 2: WATER PARAMETERS EXTRACTED BY DIFFERENT METHODS

| Measurement Methods | EM Parameter types |             |                 |                       |                     |
|---------------------|--------------------|-------------|-----------------|-----------------------|---------------------|
|                     | $h_0$ (c m)        | $h_1$ (c m) | $\epsilon_{r1}$ | $\sigma_{01}$ (m S/m) | $\alpha$ (mS/m/GHz) |
| Manual measurement  | 34                 | 3.5         | -               | -                     | -                   |
| Simulated TDR       | i/p                | i/p         | 85.1            | -                     | -                   |
| Surface reflection  | 33.76              | 3.1         | 108.6           | -                     | -                   |
| Full wave inversion | 34.09              | 3.38        | 97.77           | 50                    | 20                  |

## V. CONCLUSIONS

In this paper we have presented a simple experimental model of GPR system. It's important to select a suitable GPR modelling scheme based on application. Since EM wave propagation depends on the complex permittivity ( $\epsilon_e$ ), the GPR estimation using full wave inversion approach is demonstrated to be more accurate compared to the surface reflection method. We target to make further studies for improving accuracy and efficiency of GPR modelling and validate our measurements under practical environment.

## REFERENCES

- [1] D.J. Gunton, H.F. Scott D.J. Daniels, "Introduction to subsurface radar," *IEE PROCEEDINGS*, vol. 135, no. 4, August 1988.
- [2] David J. Daniels, Ed., *Ground Penetrating Radar*, 2nd ed. London, United Kingdom: IET, 2004.
- [3] Xiongyao Xie, Motoyuki Sato Hai Liu, "Accurate Thickness Estimation of a Backfill Grouting Layer behind Shield Tunnel Lining by CMP Measurement using GPR," in *14th International Conference on Ground Penetrating Radar (GPR)*, Shanghai, China, June 4-8, 2012.
- [4] G. Serbin and D. Or, "Ground-penetrating radar measurement of soil water content dynamics using a suspended horn antenna," *IEEE Trans. Geosci. Remote Sens.*, vol. 42, no. 8, pp. 1695–1705, Aug. 2004, vol. 42, no. 8, pp. 1695–1705, Aug 2004.
- [5] S., and J.-C. Dubois Tillard, "Analysis of GPR data: Wave propagation velocity determination," *Journal of Applied Geophysics*, vol. 33, pp. 77–91, 1995.
- [6] E. Slob, I. van den Bosch, B. Stockbroeckx, B. Scheers, and M. Vanclooster S. Lambot, "Estimating soil electric properties from monostatic ground-penetrating radar signal inversion in the frequency domain," *Water Resources Res.*, vol. 40, p. W04 205, 2004.
- [7] W. C. Chew, *Waves and Fields in Inhomogeneous Media*: IEEE Press, Piscataway, NJ, 1995.
- [8] J. A. Kong, *Electromagnetic Wave Theory*, 2, Ed.: New York: Wiley, 1990.

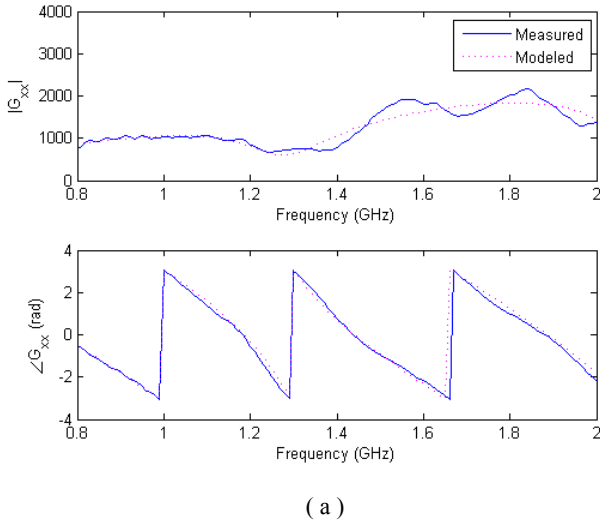

(a)

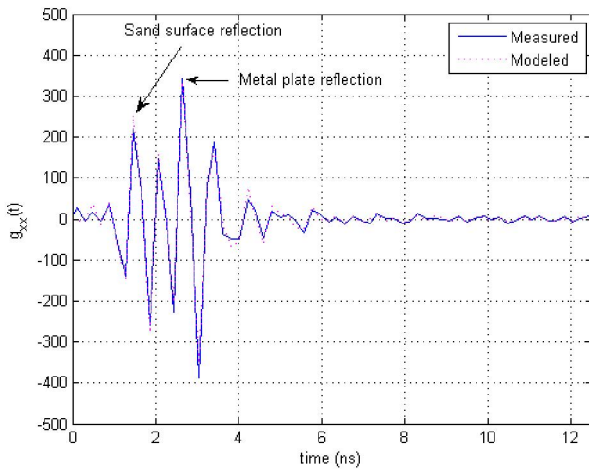

(b)

Figure 4: Measured and modelled Green's function for the wet sand represented in (a) Frequency domain and (b) Time domain.

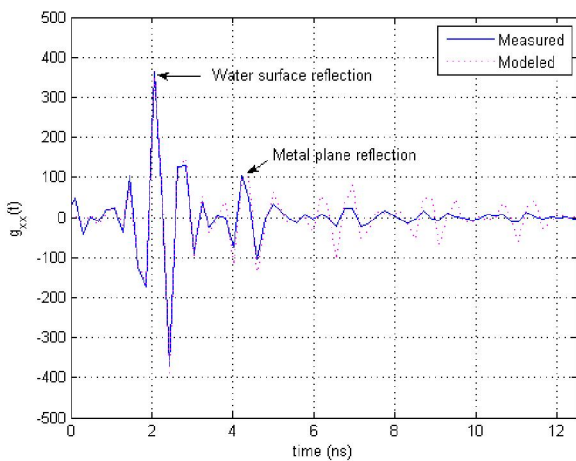

Figure 5: Measured and modelled Green's function for the water layer represented in Time domain.