

Synchronous Overloaded System for the Uplink of Cellular CDMA with Unequal Chip Delay Spreading (UCDS)

Amiya Singh
Electronics & Communication Engg. Dept.
NIT Rourkela
Rourkela, India
amiyasingh87@gmail.com

Poonam Singh
Electronics & Communication Engg. Dept
NIT Rourkela
Rourkela, India
psingh@nitrrkl.ac.in

Abstract—Channel overloading in Code Division Multiple Access (CDMA) facilitates to accommodate more number of users than the assigned spreading factor N . Our proposal for a synchronous CDMA technique for the uplink of a cellular system over additive white gaussian noise (AWGN) channel achieves oversaturation by using the same set of orthogonal Walsh Hadamard codes and a receiver with lower complexity. The technique involves dividing the total number of active users into G groups, each with L users. Each user in a group is assigned the same signature sequence but with different chip duration. Users in a group can be classified as Primary and Secondary. The Primary user avails the spreading sequence with the maximum chip duration T_c . The rest $L-1$ (secondary) users are assigned the same code with chip duration as multiples of T_c/L . Unlike conventional Direct Sequence CDMA (DS-SS-CDMA), all the users participate in spreading using the proposed Unequal Chip Delay Spreading (UCDS) technique. The receiver contains a switching unit to separate the received stream into L sub-streams followed by the detection process using a simple multi user detector. On the other hand, L levels of Unequal Error Protection (UEP) can be attained due to the unequal amount of multiple access interference (MAI) existing in alternate chip interval during transmission. Unequal chip delay spreading finally enables it to have a L -fold increase in the user data rate at the receiving end as compared to that of the transmission.

Keywords—Overloading; UCDS-CDMA; UEP; OSIC; MAI; Superposition Coding CDMA (SPC-CDMA); Collaborative Spreading CDMA (CS-CDMA)

I. INTRODUCTION

Code Division Multiple Access (CDMA) is supposed to be one of the most emerging techniques to address the overwhelming demand of the modern wireless services. The other multiple access techniques i.e. time division multiple access (TDMA), frequency division multiple access (FDMA) carry a hard limit on their capacity to accommodate more number of users on a limited spectrum. In contrast the same issue can be smartly addressed in CDMA due to its unique flexibility in maximizing the user capacity at the cost of an marginal error performance. For the conventional CDMA system employing orthogonal signature codes, a

maximum number of N users can be accommodated with better quality of service over a noisy and fading environment. For a total number of K users ($K < N$), the system is underloaded with an acceptable amount of MAI. With the total number of users exceeding the spreading gain ($K > N$), the faithfulness of the overloaded system gets significantly deteriorated due to the presence of excess multiple access interference (MAI) resulting from the non-zero cross correlation of the user signals.

Many approaches with several diversities can be found such as those reported in literature [2-7]. The use of Welch Bound Equality (WBE) sequences though achieves a significant improvement in maximizing the total number of users, but it suffers from the problem related to scalability [1]. In another scheme known as Random Orthogonal/Orthogonal (O/O) CDMA two sets of different orthogonal code are used for two sets of users [2]. In [3] a more improved random O/O CDMA has been proposed with displaced codes. In [2] [3] the use of non-linear multi user detectors with massive computations add extra complexity to the receiver side. In [7] the proposal for a group orthogonal CDMA using collaborative spreading (CS-CDMA) to achieve oversaturation implements simple receiver structure. [4] suggests an innovative approach to the overloading for CDMA by assigning the same code to more than one user but with different chip waveforms.

Superposition Coding is another technique investigated in [5] to achieve oversaturation using a single spreading sequence for more than a user. The active users are divided into G groups with each of L users. The different users in each group with the same signature code retain their unique identity by the different levels of their received power. It provides a L -fold increase in the system capacity with a degradation in the error performance. It achieves different Unequal Error Protection (UEP) levels and increased sum rate as compared to CS-CDMA [7].

In this paper, our proposal includes an overloading scheme for the uplink of a synchronous CDMA system with higher capacity and lower complexity. It splits all the active users into G groups each with L users. Each user inside a group is well accessible to the same orthogonal spreading

sequence but with different chip durations. The user with the maximum chip duration is termed as the Primary user and the rest are Secondary users with lesser chip durations. The unequal amount of delay offered to different users after each chip of the spread data makes them aligned in time with respect to each other for the purpose of easier detection. As shown in Fig. 1, at the receiver, first the signal has to be passed through a switching block in order to separate L different sub streams (r_1, r_2, \dots, r_L) for the detection of user data in a specific group. The second section of the receiver despreads and detects the user data in a group sequentially one after another using a simple Orthogonal Successive Interference Cancellation (OSIC) multiuser detector. The primary user in a group is highly error protected and protection capacity decreases with the decrease in the chip duration of the sequence. Complete system structure has been provided and evaluated over an additive white gaussian noisy (AWGN) channel. Finally the simulated results using MATLAB (R2011) platform and performance analysis with respect to the other existing overloaded schemes [5,7] has been provided.

Organizing the rest of the paper, Section-II includes the logic of unequal chip delay spreading (UCDS) along with the system model. In Section-III the multi user detection has been presented followed by the performance analysis and comparisons in Section-IV. Finally this paper has been ended with a conclusion in Section-V.

II. UPLINK SYSTEM MODEL FOR UCDS-CDMA

The prime purpose of this overloading technique is to have K number of CDMA users e.g. $K > N$ in an available code space of N . To achieve this, all the available active users are separated into G groups with each group having L number of users e.g. values of $L=2$ will lead to an overloading factor ($OF=K/N$) of 2. Due to the scarcity of completely orthogonal sequences, each user in a group has to share the same sequence but with different chip durations. The chip duration of any user is adjusted to be a multiple of T_c/L e.g. $t_c = n(T_c/L)$ where $n=1, 2, \dots, L$ and t_c =chip duration.

Hence the chip waveform of each user can be written as

$$C_l(t) = \sum_{n=1}^N s(n) g(t - (n-1)(L-(l-1))T_c/L) \quad (1)$$

The Equation (1) will generate the signature sequence for l^{th} user in a group ($l=1, 2, \dots, L$) with $g(t)$ as the chip waveform of unit energy and with chip duration as a multiple of T_c/L . N is the spreading factor of the available code space with $N=T_b/T_c$, where T_b is the bit duration of the user data.

As shown in Fig. 2, the signature code with maximum chip duration (T_c) is assigned to the primary user

and the $L-1$ secondary users are assigned a code with a chip duration of nT_c/L , where $n=1, 2, \dots, (L-1)$. In this way every user bear a signature with different chip duration to attain a separate code domain for the purpose of transmission.

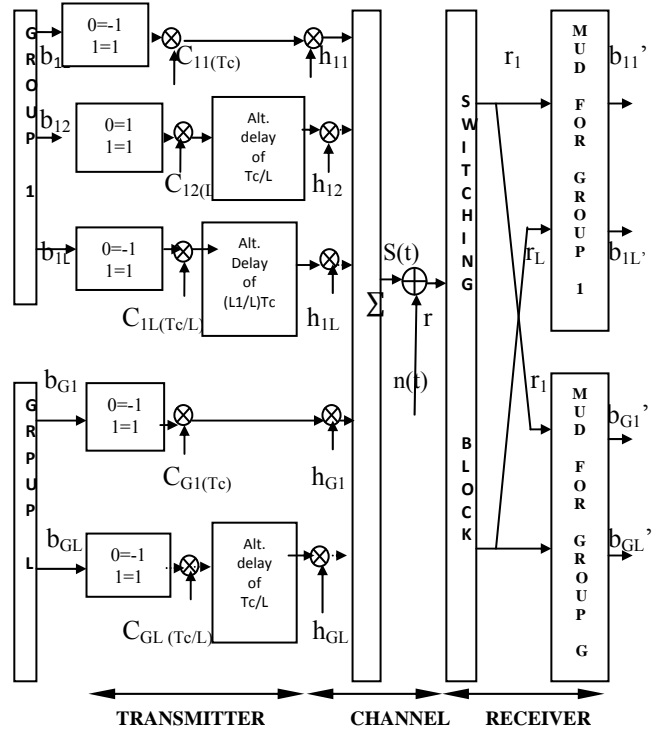

Figure 1. System Model for UCDS-CDMA

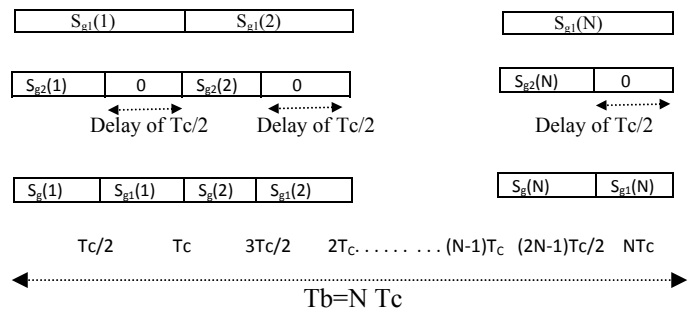

Figure 2. Unequal chip delay spreading for a single bit of data of g^{th} group with group size $l=2$. 1st row, 2nd row & 3rd row showing the transmitted sequence of User-1 (with $t_c=T_c$), User-2 (with $t_c=T_c/2$) and grouped signal of both respectively, where t_c =chip duration .

Assuming the user data to be BPSK modulated the conventional spread data without any delay can be written as

$$P_{gl}(t) = \sum_{i=-\infty}^{\infty} \sqrt{E_b} a_{gl}(i) C_{gl}(t-i T_b) \quad (2)$$

where E_b = bit energy level, a_{gl} & C_{gl} is the data bit and assigned unique code sequence for the l^{th} user in g^{th} group.

To avoid the problem of data misalignment over time frame and to access an equal time length of transmitted

data for every user, suitable but unequal amount of delay is inserted to each user's spread data alternatively. As evident from Fig. 1, delay span for a particular user varies inversely with its chip duration i.e. the primary user (with maximum chip duration T_c) is given zero delay and the user with the least chip width (T_c/L) bears the maximum delay span of $(L-1)T_c/L$. The addition of alternate and unequal delays results in the separation of the user's data in time domain with different levels of multiple access interference. In Fig. 2, the unequal chip delay spreading has been explained for 2 users ($L=2$) with chip duration of T_c and $T_c/2$ respectively. The primary user data after spreading is transmitted directly without the insertion of any alternate delay. The secondary user's spread data has to pass through an alternate delay of $T_c/2$ in to get its transmitted data properly time-aligned with that of the primary user. Assuming the uplink to be synchronous and the channel to be of additive white gaussian noise (AWGN) type with impulse response (h_{gl}) as unity ($h_{gl}=1$), each user's transmitted signal can be defined as

$$S_{gl} = P_{gl}(t) * h_{gl}(t) \quad (3)$$

where S_{gl} and $P_{gl}(t)$ are the data of l^{th} user in g^{th} group after and before spreading.

$$S_g = S_{g1} + S_{g2} + \dots + S_{gL} \quad (4)$$

where S_g is the transmitted data of all the L users in a group.

$$\text{As in Fig. 2, } S_g(1) = S_{g1}(1) + S_{g2}(1) \quad (5)$$

Finally the noisy signal prevailing at the receiving antenna end is

$$r(t) = S(t) + n(t) \quad (6)$$

In (6), $S(t)$ is the sum of the transmitted signal of all the users and $n(t)$ is the white Gaussian noise which is additive in nature .

III. MULTI USER DETECTION (MUD)

The detection of the intended signal for each user in each group is accomplished in L successive steps using a simple multiuser detection technique as shown in Fig. 4. Prior to it, the received signal has to pass through a switching block which will produce L different sub-streams ($r_1(t)$, $r_2(t)$, . . . $r_L(t)$) by collecting the samples of the signal $r(t)$ at a regular interval of T_c . It's because, as shown in Fig. 3 the data with the equal levels of MAI appears to repeat at a period of T_c . Fig. 3 explains the same scenario with TWO users per group i.e. $l=2$.

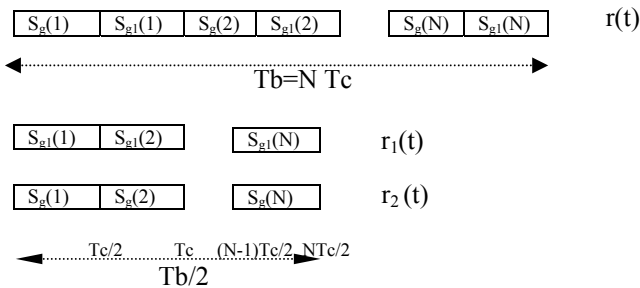

Figure 3. input & output signal of 'Switching Block' shown in Fig. 1 with Row-1 showing the input signal $r(t)$, Row-2 and Row-3 showing the output sub streams as $r_1(t)$ & $r_2(t)$ respectively.

Assuming, only one bit of each user of g^{th} group to be transmitted, two sub-streams i.e. $r_1(t)$ and $r_2(t)$ (each with a length of $NT_c/2$) have been extracted from $r(t)$ as shown in Fig. 3 which can be mathematically written as

$$r_1(t) = \sum_{n=1}^N r(t) g(t - nT_c/2) \quad (7)$$

$$r_2(t) = \sum_{n=1}^N r(t) g(t - (n-1)T_c/2) \quad (8)$$

Starting with the first chip of $r(t)$ of Fig. 3, it can be easily analyzed that the primary user's data exist in the alternative chips of transmitted signal $r(t)$ with and without the MAI. Hence the detection of the second user can only be accomplished after the detection of primary user. Hence the overall detection process consists of L stages (here $L=2$) using a L^{th} order successive cancellation receiver (OSIC). The use of OSIC receiver manifests more simplicity in design and computation as compared to the other existing non-linear MUD. Another figure which adds more simplicity to the multi stage detection process is the presence of less no of users in each group. The complexity increases with the increase in group size (l).

The multiuser detection process starts with the despreading and detection of the primary (strongly error protected) user using the sub-stream r_1 (7). A matched spreading sequence with the least chip duration (T_c/L) has to be used to separate each group's data. Hence the bits of each user is detected with a bit duration of T_b/L not T_b , which plays the major role in achieving the L -fold (here TWO-fold) enhanced data rate at the receiving side (R_r) as compared to that of the transmitting end (R_t) e.g. $R_r = L R_t$.

IV. PERFORMANCE EVALUATION AND COMPARISON

This section provides the performance analysis of our proposed UCDS-CDMA for the uplink over a synchronous AWGN. The simulated and theoretical results are compared with that of the conventional underloaded DS-CDMA, overloaded SPC-CDMA and overloaded CS-CDMA. All the user data are BPSK modulated for pass band transmission. The simulations have been performed in MATLAB (R2011) platform. For the simulation, the Walsh Hadamard sequences with the processing gain ($N=64$) have been considered for a total number of 64 groups ($G=64$). Each group carries TWO users ($L=2$) resulting in an overloading factor of TWO ($OF=2$). The same assumption are also applied to the simulation of existing SPC-CDMA and CS-CDMA.

In Fig. 5, comparing the BER of proposed UCDS-CDMA with underloaded DS-CDMA, the primary users ($tc=T_c$) appear to have a BER response completely matched with that of conventional DS-CDMA. The secondary users ($tc=T_c/2$) have lesser error protection as compared to the primary users and hence bear a cost of ≈ 0.25 dB SNR at a BER of 10^{-3} . So this figure shows the existence different levels of unequal error protection (UEP) due to the existence of multiple levels of MAI in the alternate transmitted bits. It also says that an overloading of 100% has been achieved as compared to under-loaded DS-CDMA with an additional

TABLE I. Performance comparison of different synchronous BPSK-CDMA schemes using WH sequences with $N=64$ and $G=64$ over AWGN channel

Scheme	Chip Width (1 st User)	Chip Width (2 nd User)	Sum Rate (bps)	Total Users (K)	Overloading Factor (OF= K/N)	User data rate (transmission) (bps)	User data rate (reception) (bps)	SNR(dB) at 10^{-3} BER in AWGN channel
Conventional DS-CDMA	T_c	Not Applicable	1.0	64	1	1/64	1/64	≈ 6.7
CS-CDMA	T_c	T_c	1.0	128	2	1/128	1/128	≈ 8.4
SPC-CDMA	T_c	T_c	2	128	2	1/64	1/64	≈ 7.7
UCDS-CDMA	T_c	$T_c/2$	2	128	2	1/64	1/32	≈ 6.8

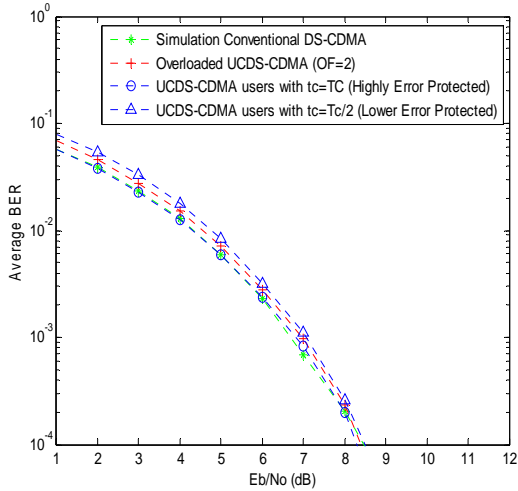

Figure 5. BER performance of the users in proposed UCDS-CDMA with different levels of UEP compared to the Underloaded DS-CDMA

power of ≈ 0.1 dB at an average BER level of 10^{-3} .

Figure-6 predicts the flexibility of the proposed scheme with respect to the SPC-CDMA with power fractions of $\gamma_1=0.2$ and $\gamma_2=0.8$ and conventional DS-CDMA. It can be easily observed that the overloaded UCDS-CDMA dominates the overloaded SPC-CDMA with a significant gain of 0.8 dB for the same system capacity with equal sum rate ($R_{\text{sum-CDMA}}$) at a BER of 10^{-3} . In [5] the overloaded SPC-CDMA has been found to achieve a gain of 0.7 dB as compared to overloaded CS-CDMA with an overloading factor of $OF=2$ and a BER of 10^{-3} . In other words the oversaturated UCDS-CDMA also outperforms the CS-CDMA [7] with a net gain of 1.5 dB with a 100% increase in its sum rate ($R_{\text{sum-CDMA}}$) for the level of average BER at 10^{-3} .

V. CONCLUSION

An overloaded synchronous CDMA system with unequal chip delay spreading (UCDS-CDMA) for the uplink over AWGN channel is proposed. In TABLE I the theoretical parameters and simulated results of BER are analyzed with respect to the other existing techniques. The study indicates the outperformance of UCDS-CDMA w.r.t other existing overloading schemes. The use of OSIC for multiuser detection makes the receiver less complex with less computations for the groups with lower size ($l=2$). The different levels of unequal error protection for different intra group users helps in achieving different individual BER response. Finally the higher data rate achieved during reception makes the proposed scheme quite unique compared to other proposed techniques in the literature.

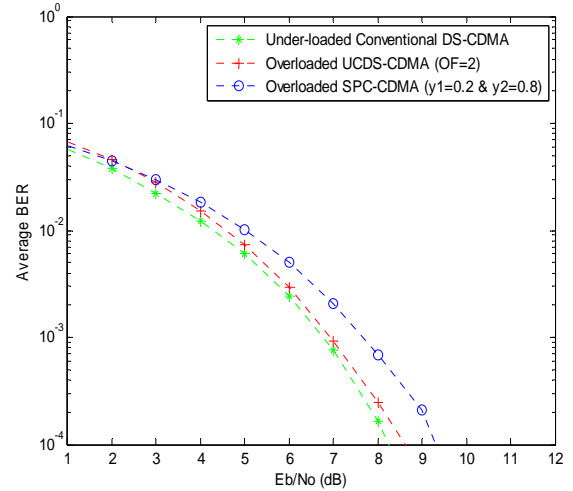

Figure 6. BER performance of the users in proposed overloaded UCDS-CDMA compared with the overloaded SPC-CDMA and conventional under loaded DS-CDMA.

REFERENCES

- [1] Welch L. Lower bounds on the maximum cross correlation of signals. *IEEE Transactions on Information Theory* 1974; 20:397-399
- [2] Vanhaverbeke F, Moneclacy M, Sari H, DS-CDMA with two sets of orthogonal sequences and iterative detection. *IEEE Communication Letters* 2000, 4:289-291
- [3] Vanhaverbeke F, Moneclacy M, An improved OCDMA/OCDMA schemes based on displaced orthogonal user sets. *IEEE Communication Letters* 2004, 8:265-267
- [4] Nguyen Ha.H, Shwedyk Ed, A New Construction of signature waveforms for synchronous CDMA systems. *IEEE Transactions on Broadcasting* 2005, 51:520-529
- [5] Tahir Yassen H.,Chee Kyun Ng,Noordin Nor K., Ali Borhnuddin Mohd., Khatun Sabira (2011). Superposition Coding with unequal error protection for the Uplink of overloaded DS-CDMA system. *Springer Wireless Personal Communication*.
- [6] Ali, F. H. & Honary, B. (1994). Collaborative coding and decoding techniques for multiple access channels. *IEE proceedings Communications*, 141(2), 56-62
- [7] Ali, F. H, Shakya I & Stipidis E. (2010). Collaborative spreading for the downlink of overloaded CDMA. *Willey Wireless Communications & Mobile Computing*. 10: 383-393.