

Energy integration of sponge iron production process

Deepthi Tirumalaraju
Department of Chemical Engineering
National Institute of Technology
Rourkela, India
e-mail: tirumalaraju.deepthi@gmail.com

Dr. Shabina Khanam
Department of Chemical Engineering
National Institute of Technology
Rourkela, India
e-mail: shabinahai@gmail.com

Abanti Sahoo
Department of Chemical Engineering
National Institute of Technology
Rourkela, India
e-mail: asahu@nitrrkl.ac.in

Abstract— The present work is an approach for conservation of energy in the coal based sponge iron industry by heat integration and incorporating certain design modifications without disturbing the SL/RN process technology involved in the sponge iron production. Although the making of sponge iron through direct reduction is being practiced in India, it still is having loopholes due to the non-optimal process parameters, high energy consumption and old running process technology motivation of the present work.

The waste heat recovery in the process is done using waste gases exiting from ESP. For this purpose a case study of typical Indian sponge iron process of capacity 100 tpd is considered. After a complex reduction and combustion process waste gas exits the sponge iron plant at substantially higher temperature which is around 200-220°C. At this range of temperature waste gas carries a lot of sensible heat which directly goes to the atmosphere through chimney.

To apply heat integration on the sponge iron production process a solution technique has been developed. A complete material and energy balance is performed on the process to obtain theoretical oxygen and there by air demand of the process. Therefore air to coal ratio is calculated, which is kept fixed for entire integration process. A model is developed to calculate the theoretical coal demand of the process based on heat of reactions, feed preheating, sensible and radiation losses, etc. Then heat integration is applied by incorporating the proposed design modifications to preheat the kiln feed and air. This reduces the amount of coal consumption to 4.3%. In addition, due to decrease in the amount of air the waste gas amount is also decreased from 27.68155t/h to 26.3698 t/h.

Keywords- *Sponge iron plant, Heat integration, Material and Energy balance*

I. INTRODUCTION

Sponge iron is a metallic mass with honeycomb structure. It is a form of iron produced from direct reduction of iron oxide below the fusion temperature of iron ore (1535°C) by utilizing hydrocarbon gases or carbonaceous fuels as coal. Sponge iron is produced primarily both by using non-coking coal and natural gas as reductant and therefore classified as coal based and gas based process respectively. Due to a promising availability of coal in India, the coal based sponge iron plants share the major amount of its production.

The availability of raw materials, high demand of sponge iron and less payback period, sponge iron industry has emerged as a profitable venture. However, due to lack of proper integration techniques, non-optimal process parameters, high energy consumption and old running process technology, the industry are facing a setback in market.

Many investigators considered the process of sponge iron manufacturing and recommended improvement in that [1, 2, 3 and 4]. It is found that during the operation in the coal based sponge iron plant, an incredible amount of heat is generated and a significant part of this heat associated with the waste gas, remains unutilized. A few authors considered this fact and suggested improvement in the process. Prasad et al. [5] investigated the utilization of heat of waste gas, through two case studies considering preheating of feed material. They compared these cases with the existing waste heat recovery system of the plant based on coal consumption and economic analysis.

The literature indicates that for Indian sponge iron industries the power consumption ranges from 45-130 kWh/t [6]. Significant improvements in decreasing energy consumption were achieved in gas based direct reduction processes. However, for coal based processes potential for such savings is required. Although many plants have

acquired the desired level of operational efficiency but from energy point of view various units is below optimum limit. The principal cost factor in direct reduction is energy cost as energy requirement for rotary kiln processes ranges between 14.63 GJ/t to 20.9 GJ/t [7].

Based on above discussion, it was observed that for heat recovery several authors have considered only heat available with waste gas; however, in the sponge iron process there are many potential areas where unutilized heat is present. Therefore, a fresh look is required on the existing process to integrate energy effectively. Thus, in the present paper, an approach is identified for energy integration and modifications based on the actual data of sponge iron plant are suggested.

II. DESCRIPTION OF CONVECTIONAL COAL BASED SPONGE IRON PLANT

The process flow sheet of a typical coal-based sponge iron plant with material and energy balanced operating data is shown in the figure. 1. The overall production capacity of the plant is 100tpd. In this process screened iron ore (6.5tph), coal (3.529tph) and dolomite (0.2tph) are charged into the rotary kiln. About 40% of total 5.958 tph coal i.e 2.429tph of slinger coal is also injected pneumatically from the discharge end of the kiln. Compressed air (24.807 tph) is injected along the length of the rotary kiln at various places with the help of blowers which can be adjusted separately.

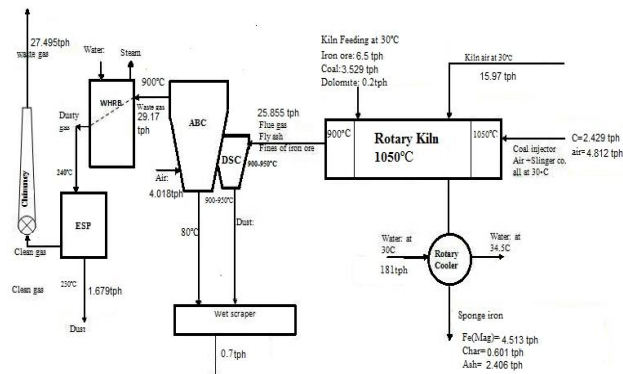

Figure 1: Flow Sheet of Typical Sponge Iron Plant

The inside kiln is lined with refractory and supported on three piers called support rollers with an inclination of 2.5°. The girth gear is used for the rotation of the kiln. Due to its inclination and rotation, material in the bed of kiln moves along the axis.

CO and CO₂ gases are produced when combustion of coal takes place in the presence of air inside the kiln. These exothermic reactions increase the temperature of coal which helps in bringing it to reaction temperature. The remaining amount of total coal is injected from the discharge end. It reacts with CO₂ to produce CO, which acts as the reducing agent to produce Fe from iron ore.

The residence time of iron ore inside the kiln is about 10 hours. During this time iron ore is reduced optimally. Hot sponge iron along with semi burnt coal exits the kiln at the discharge end. The product stream at 1000°C consists of Fe

(4.513 tph), Char (0.601 tph) and Ash (2.40 tph). This discharged material enters the rotary cooler where water is sprayed over the cooler and the temperature is brought down to about 120°C. The products, after cooling were separated into iron, char and other non-magnetic impurities using electromagnetic separators. These separated products are screened into different sizes and sent to storage.

The gases out of the rotary kiln are burnt in a chamber to ensure that CO is negligibly present. Air (4.018 tph) is fed into the After Burning Chamber (ABC) to burn the CO gases. The Waste gases from ABC at 1000°C enter the waste heat recovery boiler (WHRB). Here, waste gas is quenched to bring its temperature down to a workable limit for downstream equipment. Water, coming out from the guns, is sprayed to reduce temperature of waste gas to desired level, which is 200-250°C. The bottom part of the WHRB and ABC is attached with a wet scraper to collect the dust.

Further, waste gas coming out from the WHRB enters the electrostatic precipitator (ESP) for removal of particulate matter. Desired temperature of the waste gas is to be maintained below 200-250°C. ESP exit is connected to the chimney through an induced direct fan. After ESP, filtered waste gas goes to the atmosphere and remaining material of ESP is collected as dust.

III. HEAT INTEGRATION

The process description shows that waste gas exits the ESP at 220°C which is significantly high. The heat available with waste gas can be utilized in the process. Considering this fact the heat integration study is done in the sponge iron process by pre-heating the kiln feed mixture (iron ore, coal, dolomite) and kiln air using waste gas exiting from ESP. The waste gas from ESP is at 220°C is carried out through duct to the rotary kiln and a return duct is used to carry the waste gas from kiln to the chimney.

IV. RESULTS AND DISCUSSION

In the present work modification in the design based on the actual data of sponge iron plant is proposed where waste gas exiting from ESP is used to preheat kiln feed and air. In the actual plant feed mixture (iron ore, coal, dolomite) and air is fed into the rotary kiln at 30°C where it is preheated inside the kiln upto reaction temperature which is assumed as 1020°C. This is done by burning of coal inside the kiln. However, by preheating the kiln feed and air using waste gas outside the kiln some amount of coal may be reduced.

The temperatures of kiln feed and air are increased to 120°C and 114.5°C, respectively through preheating by waste gas. Thus, preheating of kiln feed and air is carried out from 120°C to 1020°C and 114.5°C to 1020 °C inside the kiln using combustion of coal. Thus, total coal consumption is reduced from 6.144 t/h to 5.95 t/h. The coal consumption is computed using following equations [8]:

$$Q_a + Q_o + Q_{rxn} + Q_{loss} + Q_c + Q_w = m_c \times NHV \times (0.675)$$

Where, NHV is the net heating value of coal which is 27382.267kJ/kg. However, when the consumption of coal

drops the quantity of air required to burn it also drops. So the solution of this problem requires trial and error. Based on the trial and error method the final amount of coal required is estimated to be 5.88 t/h and the corresponding air requirement comes out to be 23.74 t/h. Detailed computation for it is shown in Table 1. The outlet temperature of the kiln feed is kept constant at 120 °C due to conveying problems

TABLE I. RESULTS OF ITERATIVE APPROACH FOR COAL CONSUMPTION

| S.No | Coal consumption (tph) | Air requirement (tph) | Kiln feed outlet temperature(°C) | Air outlet temperature (°C) |
|------|------------------------|-----------------------|----------------------------------|-----------------------------|
| 1 | 6.1442 | 24.8079 | 120 | 109.94 |
| 2 | 5.9541 | 24.0405 | 120 | 113.29 |
| 3 | 5.8973 | 23.8112 | 120 | 114.33 |
| 4 | 5.8838 | 23.7566 | 120 | 114.58 |

Table 1 shows that the coal consumption is reduced by 4.3%. Due to the drop down in air requirement the heat required to preheat, which is supplied by the waste gas, will also drop. Further, due to decrease in the amount of air the waste gas amount will also decrease to 26.3698 t/h in comparison with earlier figure of 27.68155 t/h. For this modification temperature of waste gas drops down to 150°C. In fact, this is a sufficient temperature of the waste for escape out through chimney. The present modification reduces the coal consumption and waste gas generation. To achieve this modification a gas-gas shell and tube heat exchanger for air preheating and a solid-gas exchanger for the pre-heating of kiln feed is employed. However, design of these equipment is beyond the focus of the present work.

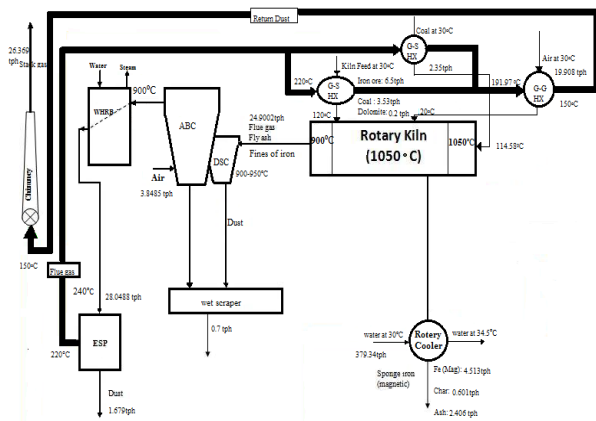

Figure 2: Modified Flow Sheet of Sponge Iron Process

Further, waste gas from ESP is brought to the rotary kiln through a duct and a return duct is used to carry the waste gas at from kiln to the chimney. Both ducts are insulated. The distance between ESP outlet and rotary kiln is 43m in plant site the insulated duct of 43m length is required. The diameter of duct, which is a hollow cylinder, is considered as

1.2m. This duct is modelled and simulated with Ansys workbench (Ver. 12) [8]. These ducts are made of steel where glass wool is used as insulating material at the outer surface of the ducts. The modified flow sheet of sponge iron process is shown in Fig. 2.

V. CONCLUSION

The salient conclusions of the work are as follows:

- The heat integration of the system was done by recovering the heat from the waste gases at 220°C. For this purpose modifications were done in the existing system where the heat available with waste gases are integrated in the process to preheat kiln feed mixture and air.
- The additional equipments required for this modification are a duct to carry the waste gases from ESP to rotary kiln, a gas-solid heat exchanger for preheating kiln feed mixture from 30°C to 120°C, a gas-gas heat exchanger for preheating kiln air from 30°C to 114.58°C and a return duct to carry the waste gases back to chimney.
- A trial and error method is followed to calculate the coal required. Based on this the final amount of coal required is estimated to be 5.88t/h and the corresponding air requirement comes out to be 23.74 t/h. 4.3 % reduction of coal is achieved.

REFERENCES

- [1] B.B. Agrawal, K.K. Prasad, S.B. Sarkar, and H.S. Ray, "Cold bonded ore-coal composite pellets for sponge ironmaking. Part 1 laboratory scale development", *Ironmaking and Steelmaking*, vol. 27, pp. 421–425, 2000.
- [2] B.B. Agrawal, K.K. Prasad, S.B. Sarkar, and H.S. Ray, "Cold bonded ore-coal composite pellets for sponge ironmaking. Part 2. Plant trials in rotary kiln", *Ironmaking and Steelmaking*, vol. 28, pp. 23–26, 2001.
- [3] S. Rani Devi, and B. Mazumder, "Recovery of Carbon From Sponge Iron Plants—Studies on Dedust Samples", *Env. Sci. Eng.*, vol. 5, pp. 11–16, 2007.
- [4] H.P. Misra, and B. Ipicol, "Indian Sponge Iron Production—Problems and Solutions", *SGAT Bulletin*, vol. 7, pp. 37–46, 2006.
- [5] A. K. Prasad, R. K. Prasad and S. Khanam, "Design Modifications for Energy Conservation of Sponge Iron Plants", *J. Therm. Sci. Eng. Appl.*, vol. 3, pp. 015001-1, 2011.
- [6] B.Sengupta, *Sponge Iron Industry Central Pollution Control Board* [online], 2004. Available from: http://www.cpcb.nic.in/upload/NewItems/NewItem_102_SPONGE_IRON.pdf [Last Accessed on March 29, 2012]
- [7] K.H. Ulrich and J.K. Tandon, "The CODIR process for India—An example for optimum coal usage and its potential for energy recovery", *Proceedings of International Conference on Alternative Routes on Iron and Steel under Indian Conditions*, Jamshedpur, India, vol 2, pp 21–25, 1988.
- [8] V. Kumar, "Heat Integration of Sponge Iron Industry" M.Tech. Thesis, National Institute of Technology, Rourkela, India, 2011.