

Design & Kinematic Analysis of an Articulated Robotic Manipulator

Elias Eliot¹, B.B.V.L. Deepak^{1*}, D.R. Parhi², and J. Srinivas²

¹Department of Industrial Design, National Institute of Technology-Rourkela

²Department of Mechanical Engineering, National Institute of Technology-Rourkela

*Email: bbv@nitrkl.ac.in, Tel.: +91-661-246-2514

Abstract: This paper describes the design, fabrication and analysis a five axes articulated robotic manipulator. The current work is undertaken by considering various commercially available robotic kits to design and fabricate a five degree of freedom (D.O.F) arm. Forward kinematic model has been presented in order to determine the end effector's position and orientation. Although this work is still in primary level, this analysis is useful for path tracking of an industrial manipulator with 'pick-and-place' application. Based on this analysis, a researcher can develop path tracking behaviour of an end effector in complicated work space.

Key words: 5-DOF robotic arm, 5-axes articulate robotic manipulator, kinematic analysis

I. Introduction

Industrial robots are not completely androids that mimic human, but are more anthropomorphic in nature, in the sense that they are designed with resemblance to a human hand; and are also incapable of self-movement.

The requirement graph for these industrial robots has always been an upward one. Faster robots with multiple functions to increase production and reduce manufacturing cost are the necessity of the day. Factors such as: better precision, accuracy and repeatability; maximum load carrying capacity and work space and versatile operating environments are being given utmost importance during the development of any industrial robot.

The history of industrial automation [1-2] is characterized by periods of rapid change in popular methods. Either as a cause or, perhaps, an effect, such periods of change in automation techniques seem closely tied to world economics. Use of the industrial robot, which became identifiable as a unique device in the 1960's, (along with computer aided design (CAD) systems, and computer sided manufacturing (CAM) systems), characterizes the latest trends in the automation of the manufacturing process. Industrial robots were studied independently as complex manipulator arms by various authors. The kinematic modelling and analysis of a 5-axis stationary articulated robotic arm has been conducted by Manjunath [3]. Using C++ language, it was shown visually the kinematic model incorporating obstacle avoidance algorithms for the pick and place operation. Hernandez *et al.* [4] integrated two Barrett WAM arms on top of a Segway RMP mobile base by putting together power sources, computers, and distributed software systems. Instead of using locally engineered and built components, they used commercially available components to assemble a mobile manipulator. Xu *et al.* [5] systematically analysed the forward and inverse kinematics of a five DOF manipulator and suggested an analytical solution for the manipulator to follow a given trajectory while keeping the orientation of one axis in the end-effector frame. Alpha II is a five axis articulate robot arm manufactured by Microbot [6] which has a variety of standard or specialized gripper mechanisms. It is a low-cost robot system designed specifically to help manufacturing operations management, improve productivity

by automating low-level tasks that human workers find hazardous or difficult to repeat accurately for long periods of time. Rhino XR-3 [7] is also a five axis articulate robotic manipulator. This robotic manipulator has a rugged open design, which makes it very easy to study. Using this robot as a major reference all successive works have been carried out.

The present work aims to apply forward kinematics to a 5 DOF articulated manipulator. Simulation results are presented for the modelled manipulator which represents the path tracking of each individual link of the manipulator with respect to its base position. Although this work is still in primary level, this analysis is useful for path tracking of an industrial manipulator with 'pick-and-place' application.

II. Design Details

After giving a thorough consideration of all the preceding works in this field, a five degree of freedom multi-functional reprogrammable manipulator having variable programmed motions to carry out variety of tasks in diverse environments is chosen. This is a five axis articulate manipulator designed to move material like machine parts, tools, specialized devices, etc. Fig.1 shows the different degrees of freedom of the arm. It is driven by six servomotors and has a gripper as an end-effector. The gripper has fingers with rubber lining for firm grasping and manipulation of objects as big as a 200ml bottle and having a weight of about 200gms throughout the arm's workspace.

Design's practical functions include:

Movement: The manipulator's workspace comprises of a 350 degree hemispherical envelop round itself throughout the arm's length.

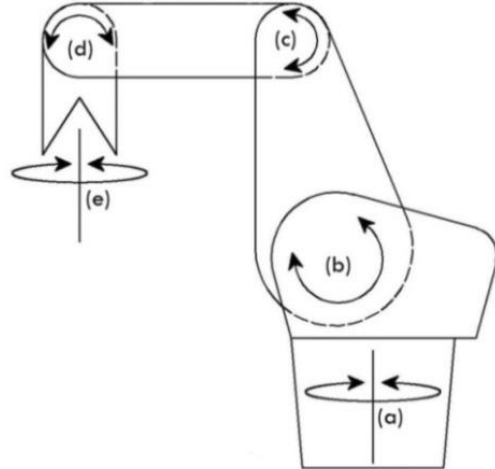

(Fig.1) Industrial Articulated Arm with Five Degrees of Freedom

Manipulation: Servo motors coupled to a chain and sprocket system are used for the movement of the arm.

Power Source: It is powered by batteries as it could be used in different environment. The manipulator can also be electrically powered when directly connected to the electric power supply with an AC/DC adaptor.

III. Concept Design and Analysis

Using CATIA, a three dimensional design of the manipulator was created (Fig. 2) to study its behaviour. An effort was put to understand finer details like physical structure and drive mechanism, to finalise on an optimum design for the manipulator.

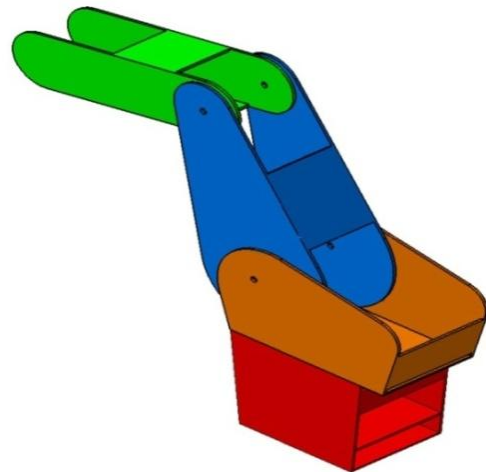

(Fig.2) Proposed manipulator

The robotic manipulator is built in-likeness to a Rhino XR-4. Upon conducting literature survey it was found that to construct a robot in-likeness to Alpha II or Rhino XR-4 was advisable as these manipulators had the best designs when stability and balance were considered. Few of these details from the three dimensional model are given in *Table 2*.

Table 2

Basic Specification of The Manipulator	
Specification	Value
Number of axes	5
Horizontal reach	460 mm
Vertical reach	570 mm
Drives	6 PMDC servo motors
Configuration	5 Axes plus gripper All axes completely independent All axes can be controlled simultaneously
Work Envelope	Refer (<i>Fig. 1</i>) (a) Body Rotation -350 degrees (b) Shoulder Rotation -150 degrees (c) Elbow Rotation -180 degrees (d) Wrist Rotation -180 degrees (e) Gripper Rotation -90 degrees

Fig.3 shows the work envelope and dimensional details of the manipulator as per the data in the table above.

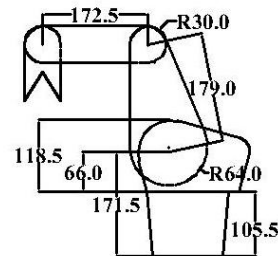
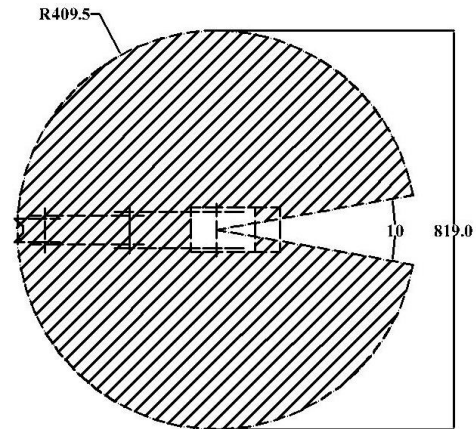
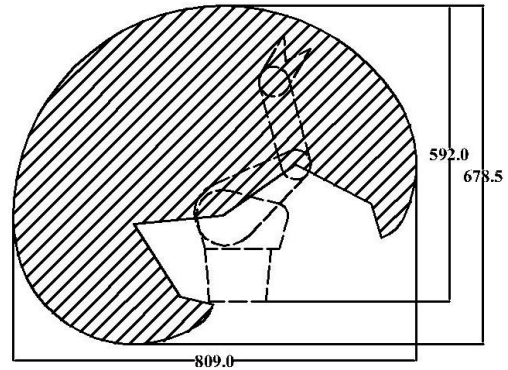
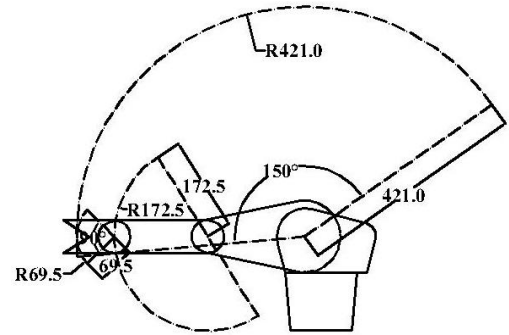

(All Dimensions in MM)

(Fig.3) Manipulator Design Specification

IV. Mathematical Formulation

Kinematics of the manipulator deals with each moveable part of the robot by assigning it a frame of reference and since the manipulator has many parts, it has many individual frames. An analysis of the links at different position is methodically calculated. The relationship between the associated forces, motion and torques is also studied. The Fig.4 shows a few positions of the arm produced by the movement of different joints.

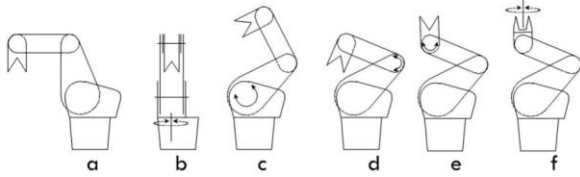

(Fig.4) Various Motions of the Manipulator Parts

Using Denavit - Hartenberg (DH) convention, coordinate frames for the manipulator are assigned as shown in the Fig.5.

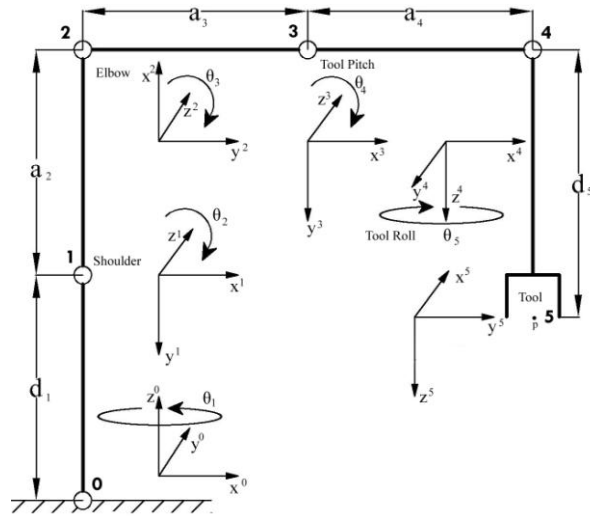

(Fig.5) Link Coordinate Frame of the Manipulator

The position and orientation of the end-effector in terms of given joint angles is calculated using a set of equations and this is forward kinematics. This set of equations is formed using DH

parameters obtained from the link coordinate frame assignment. The parameters for the manipulator are listed in Table 4, where θ_i is the rotation about the Z-axis, α_i rotation about the X-axis, d_i transition along the Z-axis, and a_i transition along the X-axis.

Table 4

<i>Kinematic Parameters of The Manipulator</i>				
Axis	θ	d (mm)	a (mm)	α
1	θ_1	$d_1 = 195$	0	$-\pi/2$
2	θ_2	0	$a_2 = 170$	0
3	θ_3	0	$a_3 = 170$	0
4	θ_4	0	$a_4 = 1$	$-\pi/2$
5	θ_5	$d_5 = 125$	0	0

The set of link coordinates assigned using DH convention is then transformed from coordinate frame (k_i) to (k_{i-1}), where k is the joints, using a homogeneous coordinate transformation matrix given in eq. (1).

$$A_i = Rot(z, \theta_i) Trans(0, 0, d_i) Trans(a_i, 0, 0) Rot(x, \alpha_i)$$

$$= \begin{bmatrix} \cos(\theta_i) & -\sin(\theta_i)\cos(\alpha_i) & \sin(\theta_i)\sin(\alpha_i) & \alpha_i\cos(\theta_i) \\ \sin(\theta_i) & \cos(\theta_i)\cos(\alpha_i) & -\cos(\theta_i)\sin(\alpha_i) & \alpha_i\sin(\theta_i) \\ 0 & \sin(\alpha_i) & \cos(\alpha_i) & d_i \\ 0 & 0 & 0 & 1 \end{bmatrix} \quad (1)$$

On substituting the DH parameters in Table 4 into eq. (1), we get individual transformation matrices T_0^1 to T_4^5 , and a global matrix of transformation T_0^5 as in eq. (2):

$$T_0^5 = T_0^1 T_1^2 T_2^3 T_3^4 T_4^5 = \begin{bmatrix} m_x & n_x & o_x & p_x \\ m_y & n_y & o_y & p_y \\ m_z & n_z & o_z & p_z \\ 0 & 0 & 0 & 1 \end{bmatrix} \quad (2)$$

where (p_x, p_y, p_z) represents the position and $(\{m_x, m_y, m_z\}, \{n_x, n_y, n_z\}, \{o_x, o_y, o_z\})$ the orientation of the end-effector given by the eqs.(3) to (14).

$$m_x = C_1 C_{234} C_5 + S_1 S_5 \quad (3)$$

$$m_y = S_1 C_{234} C_5 - C_1 S_5 \quad (4)$$

$$m_z = -S_{234} C_5 \quad (5)$$

$$n_x = -C_1 C_{234} S_5 + S_1 C_5 \quad (6)$$

$$n_y = -S_1 C_{234} S_5 - C_1 C_5 \quad (7)$$

$$n_z = S_{234} S_5 \quad (8)$$

$$o_x = -C_1 S_{234} \quad (9)$$

$$o_y = -S_1 S_{234} \quad (10)$$

$$o_z = -C_{234} \quad (11)$$

$$p_x = C_1(a_2 C_2 + a_3 C_{23} + a_4 C_{234} - d_5 S_{234}) \quad (12)$$

$$p_y = S_1(a_2 C_2 + a_3 C_{23} + a_4 C_{234} - d_5 S_{234}) \quad (13)$$

$$p_z = d_1 - a_2 S_2 - a_3 S_{23} - a_4 S_{234} - d_5 C_{234} \quad (14)$$

Here $C_i = \cos(\theta_i)$, $S_i = \sin(\theta_i)$, $C_{ij} = \cos(\theta_i + \theta_j)$, $S_{ij} = \sin(\theta_i + \theta_j)$, $C_{ijl} = \cos(\theta_i + \theta_j + \theta_l)$, $S_{ijl} = \sin(\theta_i + \theta_j + \theta_l)$.

From this transformation matrix, the position (translation) of end-effector with reference to base frame as a function of the joint angles is depicted in Fig.6 and Fig.7.

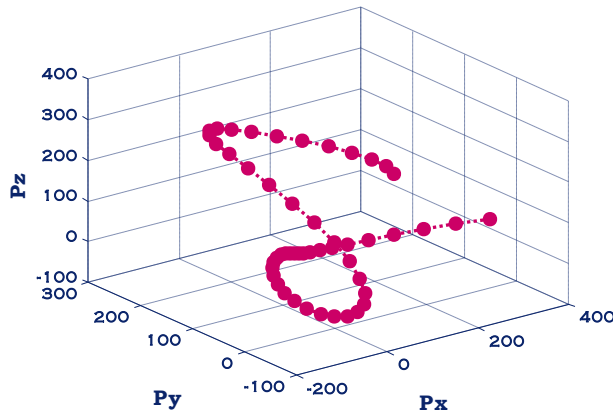

(Fig.8) Variation of End-Effector Position Vector when all Joint Angles are varied uniformly and simultaneously.

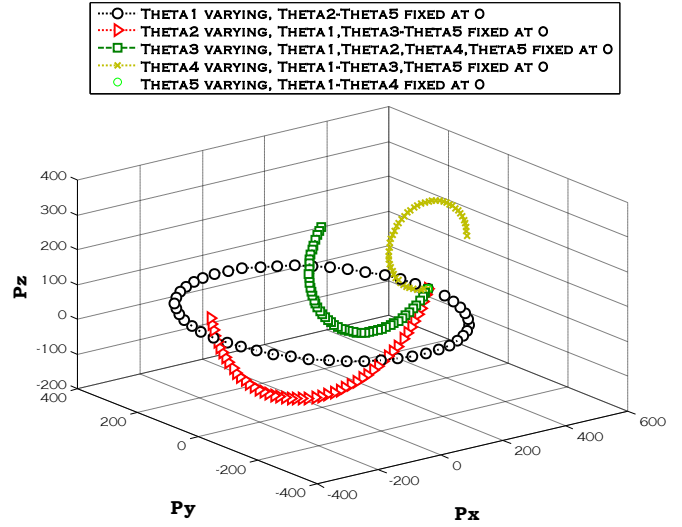

(Fig.7) Variation of End-Effector Position Vector when one Joint Angle is varied while others are Zero.

V. Conclusion

In this paper various designing and fabricating aspects of a 5 - DOF manipulator has been described briefly. With reference to many available manipulators and mobile platforms in market, a practical design for the manipulator has been perceived and computer aided designing tools like CATIA and AutoCAD are used to model the desired manipulator. As the construction of the manipulator nears end; simulation using graphical simulator is underway. Theoretical analysis of the forward kinematics was carried out to determine the end effector's position and orientation.

As a future work, comparison of the theoretical result obtained from the current analysis with the experimental results of a real robotic manipulator (5 DOF). Moreover, inverse kinematic models are necessary to determine the joint variable as the desired tool position and orientation is used to formulate of the manipulation tasks.

REFERENCES

- [1]. Robert J. Schilling, “*Fundamentals of Robotics: Analysis & Control*”, Prentice Hall, Inc., 2011 edition.
- [2]. John J. Craig, “*Introduction to Robotics: Mechanics & Control*”, Pearson Publishing, 2008 edition.
- [3]. T.C. Manjunath, “*Kinematic Modelling and Maneuvering of A 5-Axes Articulated Robot Arm*”, World Academy of Science, Engineering and Technology, pp.364-370, 2007.
- [4]. Alejandro Hernandez-Herdocia, Azad Shademan& Martin Jagersand; “*Building a Mobile Manipulator from Off-the-Shelf Components*”; 2010 IEEE/ASME International Conference on Advanced Intelligent Mechatronics Montréal, Canada, July 6-9, 2010.
- [5]. De Xu, Carlos A. Acosta Calderon, John Q. Gan, Huosheng Hu & Min Tan; “*An Analysis of the Inverse Kinematics for a 5-DOF Manipulator*”; International Journal of Automation and Computing pp.114-124, February 2005.
- [6]. “*Alpha II*”, Microbot, Michigan, USA.
- [7]. “*Rhino XR-4*” 5-axis articulate robot; Rhino Robots, Inc., Illinois, USA.