

SYNCHRONOUS VIRTUAL GRID FLUX ORIENTED CONTROL OF GRID SIDE CONVERTER FOR DISTRIBUTED POWER GENERATION SYSTEM

B.Vasantha Reddy, B.Chitti Babu, K.B.Mohanty and A.K.Panda

Department of Electrical Engineering, National Institute of Technology, Rourkela, ORISSA

E-mail: vasanth253@gmail.com, bcbabunitrkl@ieee.org, kbm@nitrkl.ac.in, akpanda.ee@gmail.com

INTRODUCTION

Due to depletion of fossil fuels and their possible pollution to the environment, the conventional energy sources are limited and more attention and interest have been paid on the utilization of renewable energy sources such as wind energy, fuel cells and solar energy etc. Distributed power generation is alternative source of energy to meet rapidly increase energy consumption. However, due to intermittent power production by DPGS, they can't be directly connected to the utility grid which causes power quality problems [1]. Due to advent of power electronic devices and technology, double sided PWM converters are used to interface DPGS with utility grid as they match the characteristics of the DPGS and the requirements of the grid connections. Power electronics converters usually improve the performance of DGPS and increase the power system control capabilities, power quality issues, system stability etc [2].

Rapidly increase in number of DGPS's leads to complexity in control while integrating into utility grid. As a result, requirements of grid connected converters become rigorous and quite difficult to meet high power quality standards like unity power factor, less harmonic distortion, active and reactive power control, fast response during transients and dynamics in the grid etc [3]. Hence the control strategies applied to DPGS become of high interest and need to be further investigated and developed.

In this paper, a virtual grid flux oriented vector control (outer loop control) and modified ramp type current controller (inner current control loop) techniques are proposed, with main focus on DC link voltage control, harmonic distortion, constant switching frequency, unity power factor operation of inverter. Vector control of grid connected inverter is similar to vector control of ac electric machine. Vector control uses decoupling control for active and reactive power control. The control structure for the vector control of grid connected converter consists of two control loops. The inner control loop controls the active and reactive grid

current components. The outer control loop determines the active current reference for controlling the dc link voltage. A cascaded control system, such as vector control is a form of state feedback. One important advantage of state feedback is that the inner control loop can be made very fast. For vector control, current control is the inner control loop. The fast inner current control nearly eliminates the influence from parameter variations, cross coupling, disturbances and minor non-linearity in the control process. Vector control uses PI-controllers in order to improve dynamic response and to reduce the cross coupling between active and reactive powers. Modified ramp type current controller is used as inner current loop; in this controller ramp signal is generated at particular constant frequency to minimize the current error. The proposed control system is simulated in MATLAB/simulink environment and results of DC link voltage, grid currents, active and reactive powers, power factor are presented.

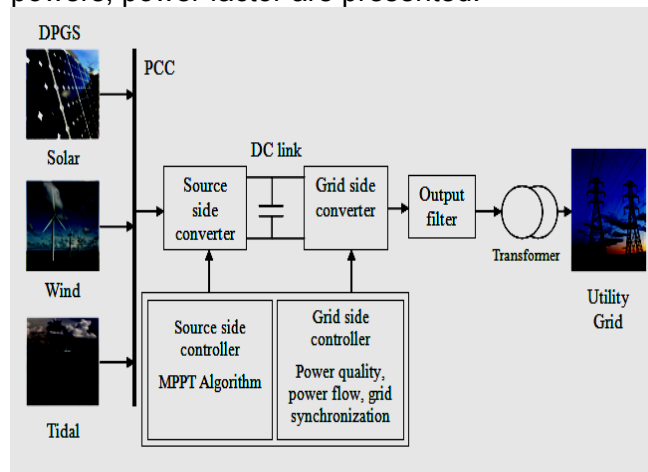

Figure 1 general structure of DPGS

CONFIGURATION OF DPGS AND ITS CONTROL

The basic configuration of DPGS is shown in fig.1. The system consists of renewable energy sources (wind, solar tidal etc.), two PWM back-to-back converters with conventional pulse width

modulation techniques, grid filter, transformer and utility grid. The source-side converter, controlled by a source-side controller, normally it ensures the maximum power point tracking (MPPT), and transmits the information about available power to the grid-side converter.

The main function of the grid-side converter is to interact with the utility grid [4]. The controller in the grid side controls active power sent to the utility grid, control of reactive power exchanged between the DPGS and the grid, control of the DC-link voltage, improvement of power quality and grid synchronization etc. Grid filter and transformer eliminates higher order harmonics in the inverter output voltage and ensures proper synchronization of the inverter with the utility grid.

a) Grid connection requirements

The basic requirements of interfacing DPGS with the utility grid are as follows, the voltage magnitude and phase must be equal to the desired magnitude and direction of the power flow. The voltage is controlled by the transformer turn ratio and/or the rectifier inverter firing angle in a closed-loop control system. The frequency must be exactly equal to that of the grid, or else the system will not work. To meet the exact frequency requirement, the only effective means is to use the utility frequency as a reference for the inverter switching frequency.

In the earlier stage, control and stabilization of the electricity system as taken care only by large power system like thermal, nuclear etc. Due to large penetration of DPGS the grid operators requires strict interconnection called grid code compliance. Grid interconnection requirements vary from country to country. Countries like India where the wind energy systems increasing rapidly, a wind farm has to be able to contribute to control task on the same level as conventional power plants, constrained only by limitation of existing wind conditions. In general the requirements are intended to ensure that the DPGS have the control and dynamic properties needed for operation of the power system with respect to both short-term and long-term security of supply, voltage quality and power system stability etc [5]. In this paper most significant performance index is studied (i.e. improvement of power quality. The power quality measurement is accessed by measure of harmonic distortion and unity power factor.

b) Concept of Virtual grid flux oriented control

Virtual grid flux oriented control of grid connected PWM converter has many similarities with vector control of ac electric machine. In fact grid is modeled as a synchronous machine with constant frequency and constant magnetizing flux. A virtual grid flux can be introduced in order to fully acknowledge the similarities between the electric machine and grid. In space vector theory, the virtual grid flux becomes a space vector that defines the rotating grid flux oriented reference frame as shown in fig.2. The grid flux vector is aligned along d-axis in the reference frame, and grid voltage vector is aligned with q-axis. Finding the position of grid flux vector is equivalent to finding the position of the grid voltage vector. An accurate field orientation can be obtained since the grid flux can be measured. The grid currents are controlled in a rotating two-axis grid flux orientated reference frame. In this reference frame, the real part of the current corresponds to reactive power while the imaginary part of the current corresponds to active power. The reactive and active power can therefore be controlled independently since the current components are orthogonal. Accurate field orientation for a grid connected converter becomes simple since the grid flux position can be derived from the measurable grid voltages. The grid flux position is given by

$$\cos(\theta_g) = \frac{e_{g\beta}}{|e_g|}, \quad \sin(\theta_g) = -\frac{e_{g\alpha}}{|e_g|} \quad (1)$$

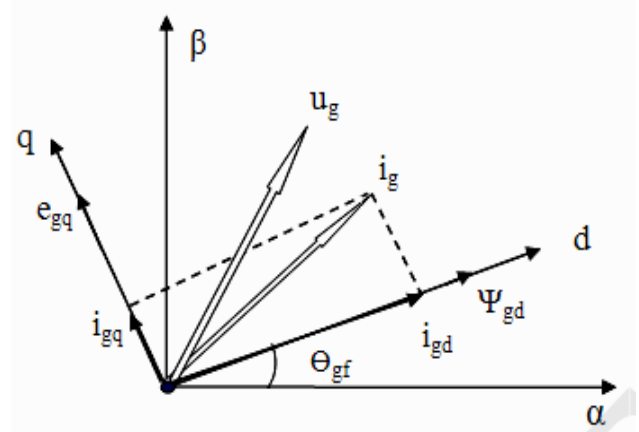

Figure 2 Virtual grid flux oriented reference frame

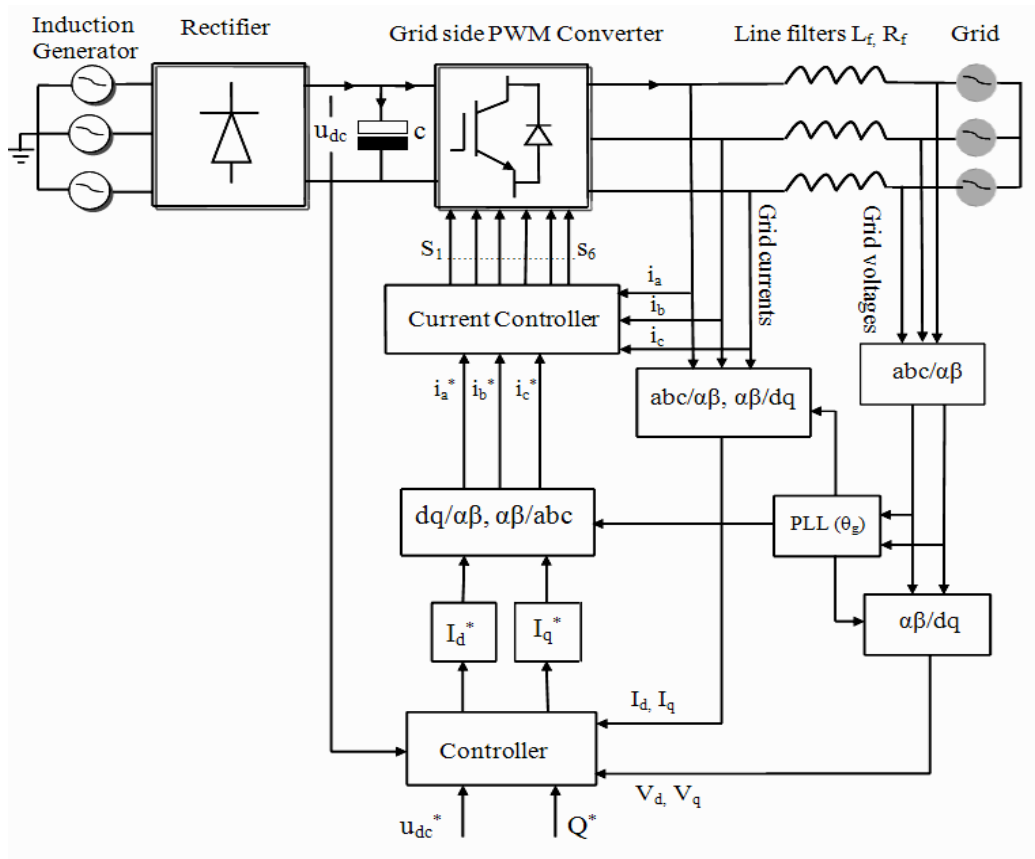

Figure 3 Block diagram of virtual grid flux control of grid connected VSI

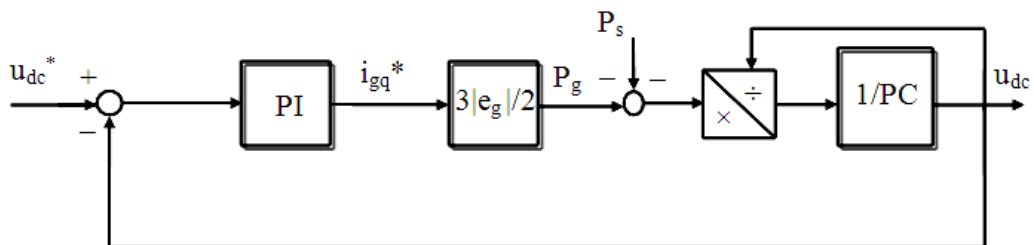

Figure 4 Block diagram of closed loop control of DC link voltage

c) Control scheme for grid connected VSI

The schematic diagram of purposed system is shown in fig .3. The control system (1) of vector controlled grid connected converter here consisting two control loops. The inner control loop incorporated with modified ramp type current controller which controls the active and reactive grid current components. The active current component is generated by an outer direct voltage control loop and the reactive current reference can be set to zero for a unity power factor. The grid currents are controlled in a rotating two-axis grid flux orientated reference

frame. In this reference frame, the real part of the current corresponds to reactive power while the imaginary part of the current corresponds to active power. The reactive and active power can therefore be controlled independently since the current components are orthogonal.

i) DC voltage controller (outer loop)

The following derivation of direct voltage controller assumes instantaneous impressed grid currents and perfect grid flux orientation. The instantaneous power flowing into grid can be written as

$$S_g = P_g + jQ_g = \frac{3}{2} e_g i_g^* = \frac{3}{2} (|e_g| i_q + j |e_g| i_d) \quad (2)$$

$$S_g = \frac{3}{2} (|e_g| i_q + j |e_g| i_d) \quad (3)$$

The active power is real part of eq.3.

$$P_g = \frac{3}{2} |e_g| i_{gq} \quad (4)$$

When neglecting capacitor leakage, the direct voltage link power is given by

$$P_{DC} = u_{DC} i_{DC} = u_{DC} C \frac{du}{dt} \quad (5)$$

Assuming the converter losses are neglected, the power balance in the direct voltage link is given by

$$u_{DC} C \frac{du_{DC}}{dt} = -P_s - P_g = -P_s - \frac{3}{2} |e_g| i_{gq} \quad (6)$$

Where P_s is the distributed energy system power is assumed to be independent of the DC voltage. A transfer function of between direct voltage and active grid current I_g is obtained as

$$u_{DC} \approx - \frac{3 |e_g|}{2 p C u_{DC}} i_{gq} \quad (7)$$

The transfer function is non-linear. It is acceptable to substitute the direct voltage with the reference set value since the objective is to maintain a constant direct voltage. The assumption gives linear zed transfer function.

$$u_{DC} \approx - \frac{3 |e_g|}{2 p C u_{DC}^*} i_{gq} \quad (8)$$

Applying internal model control gives the direct voltage link controller as

$$F = \frac{\alpha}{p} G^{-1} = -\alpha \frac{2 C u_{DC}^*}{3 |e_g|} \quad (9)$$

From eq.8, a P-controller is obtained for regulating the direct voltage. The P- controller is optimal for an integrator process in the sense that the P- controller eliminates the remaining error for steps in the reference value. However, there will be a remaining error for steps in the reference value. However, there will be a remaining error when the grid is loaded and active power flows between the direct voltage link and the grid. The remaining error can be

eliminated by adding an integrator to the direct voltage link controller. The following is often adapted for selecting the controller integration time in traditional PI-controller design.

$$T_i = \frac{10}{\omega_c} \approx \frac{10}{\alpha} \quad (10)$$

The active reference current of the grid connected converter can be written as

$$i_{gq}^* = K_p \left(1 + \frac{1}{T_i p}\right) (u_{dc}^* - u_{dc}) \quad (11)$$

$$k_p = -\alpha \frac{2 C u_{dc}^*}{3 |e_g|} \quad (12)$$

Negative proportional gain is because the distributed energy source references are used for grid. A block diagram that represents the direct voltage control is shown in Fig. 5. Note that closed-loop bandwidth of the current control is assumed to be much faster than the closed-loop bandwidth of the direct voltage link.

ii) Open loop reactive power control (outer loop)

The reactive power flowing into grid is controlled by the reactive current component. Simplest form of controlling reactive power is through open loop control. Taking imaginary part of eq.3 reactive reference current as

$$i_{gd}^* = \frac{2}{3 e_{gq}} Q_g^* \quad (13)$$

The i_{gq}^* and i_{gd}^* current references are converted into three phase current references i_a^* , i_b^* , i_c^* which are given to current controller.

iii) Action of Phase locked loop (PLL)

The implementation of the grid voltage orientation requires the accurate and robust acquisition of the phase angle of the grid voltage fundamental wave, considering strong distortions due to converter mains pollution or other harmonic sources. Usually this is accomplished by means of a phase locked loop (PLL). PLL determines the position of the virtual grid flux vector and provides angle (θ_g) which is used to generate unit vectors $\cos(\theta_g)$, $\sin(\theta_g)$ for converting stationary two phase quantities in stationary reference frame into rotating two phase quantities in virtual grid flux oriented reference frame. PLL is ensures the phase angle

between grid voltages and currents is zero. That means PLL provides displacement power factor as unity.

iv) Modified ramp type current controller (inner current loop)

Modified ramp type current controller was advanced to ramp type current controller where the magnitude and phase errors are eliminated by providing phase shift between three ramp signals. Ramp signal is generate at constant frequency which is called carrier frequency, in which inverter is operate at this constant switching frequency. The basic block diagram of modified ramp type current controller is shown in fig.6. The reference currents i_a^* , i_b^* , i_c^* compared with grid currents i_a , i_b , i_c and error signal is compared with ramp signal and is passed through hysteresis band to eliminate the multiple crossings of ramp signal with error signal. Hysteresis band generates switching pulses to inverter in such a way that grid currents follow the reference currents.

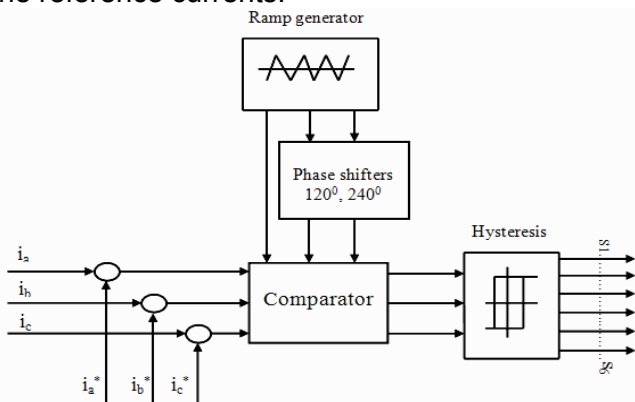

Fig.5. Modified ramp type current controller

SIMULATION RESULTS AND DISCUSSION

The proposed virtual grid flux vector control of grid connected inverter is simulated in MATLAB/simulink environment. Results of direct link voltage, grid currents, harmonic spectrum of grid current, active and reactive power, displacement power factor are shown.

Control parameter values

The reference value of direct link voltage $u_{dc}^* = 2200V$, reference value of reactive power $Q^* = 0$ to maintain unity power factor.

$K_p = 0.01$

$K_i = 60$

Hysteresis band $H = 20$. Switching frequency = 2 kHz.

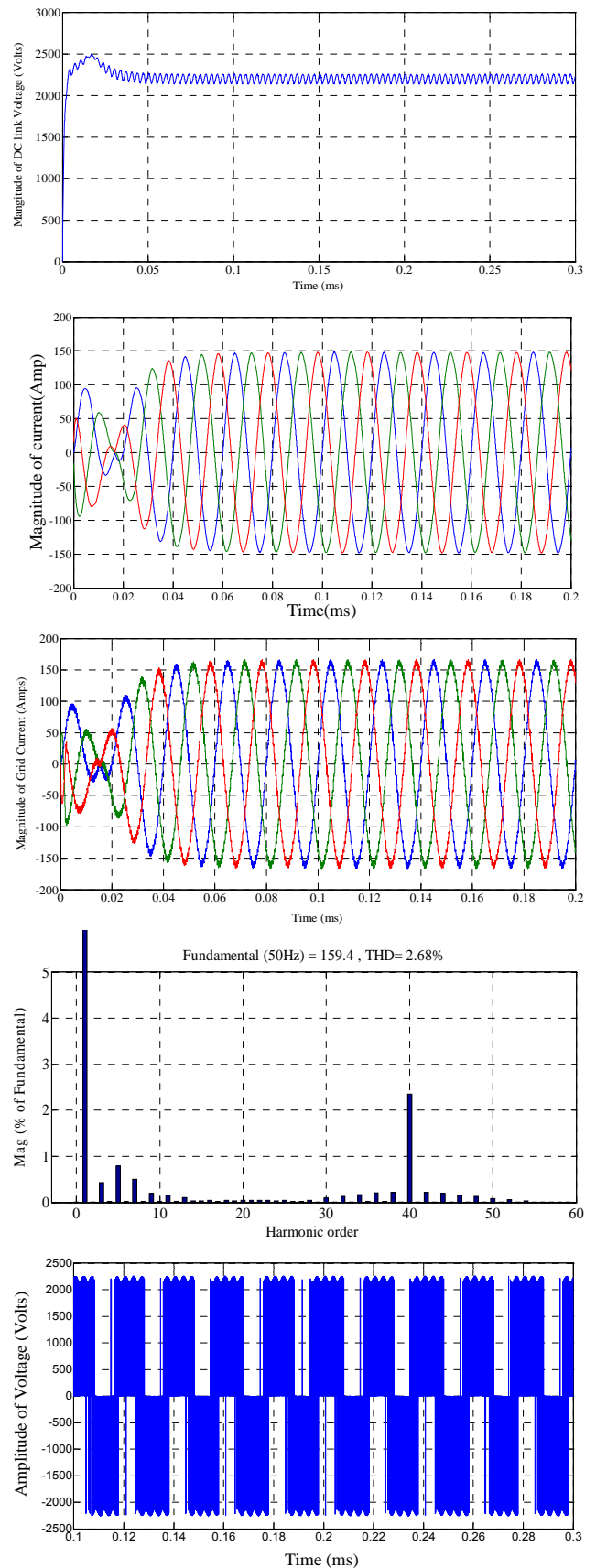

Figure 6 (a) DC link voltage (b) reference currents (c) grid currents (d) harmonic spectrum of grid current (e) inverter output voltage.

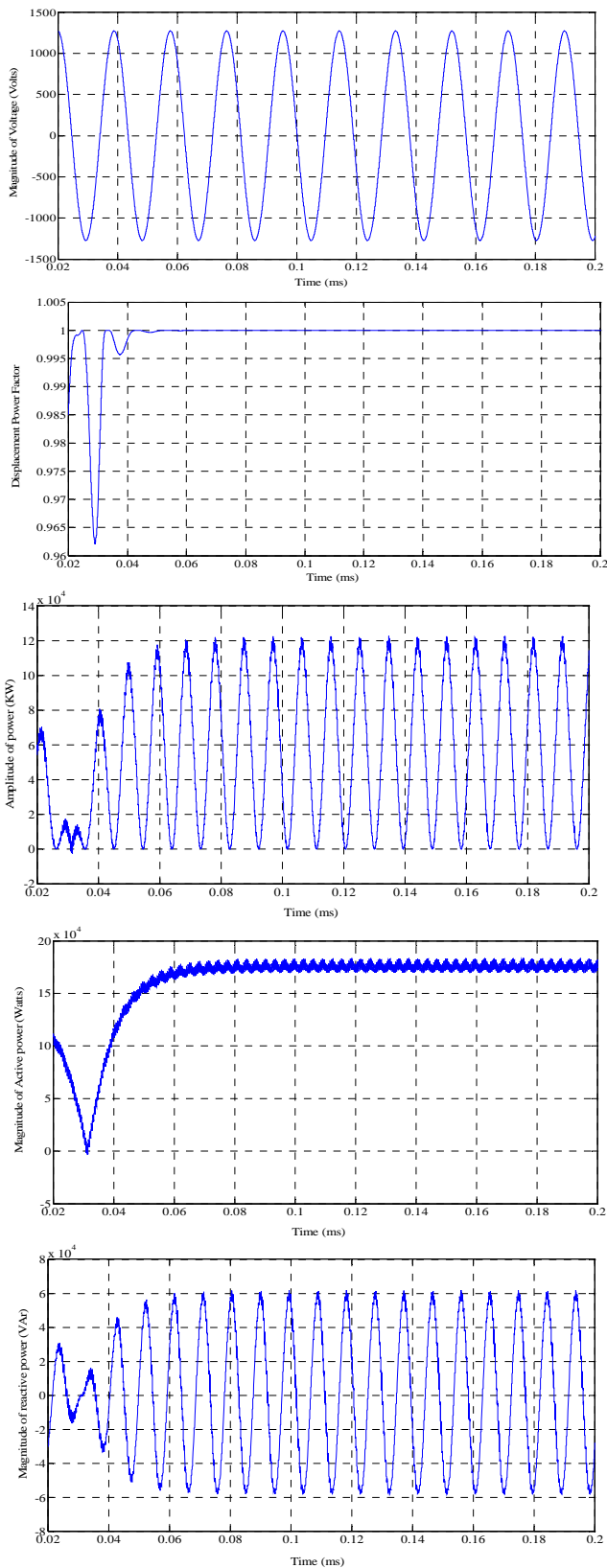

Figure 7 (a) inverter output voltage after filter (b) displacement power factor (c) single phase instantaneous active power. (d) Three phase active power (e) single phase instantaneous reactive power.

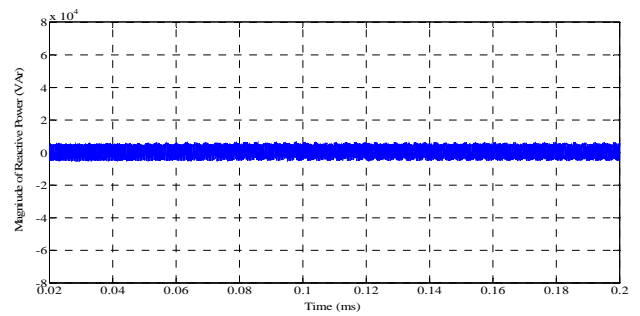

Figure 8 (a) three phase reactive power

In this section simulation results of grid connected voltage source inverter are given. Fig 6(a) shows the DC link voltage which is maintained at the set reference value and it has some ripple voltage this ripple because of rectifier output voltage is controlling by inverter. Fig 6(c) grid current waveforms which are follow the reference current waveforms. Fig 6(d) shows the harmonic spectrum of load current 40th harmonic having higher magnitude compared to other harmonics this is because of inverter is operating at 2 KHz frequency and THD of 2.68%. Fig 6 (e), 7(a) shows output voltage of inverter without and with filter. Fig 7 (b) shows the displacement power factor between grid voltages and currents which is unity. Fig.7 (c), (d) shows the instantaneous and average active power flowing into grid. Fig 7(e), 8(a) shows the instantaneous and average reactive powers flowing into grid. Form fig.6 (a) average reactive power flowing into grid is zero, and then we can say that active power is delivering to grid almost at unity power factor.

$$DF = \frac{1}{\sqrt{1 + THD^2}} = \frac{1}{\sqrt{1 + 0.0268^2}} = 0.999$$

$$\text{Power factor} = DPF * DF = 1 * 0.999 = 0.999$$

CONCLUSION

Virtual grid flux orientated vector control of grid side inverter for distributed power generating system is discussed in this paper. From that we observed that the ramp type current controller on the inner current control loop gives good dynamic response. Also it provides decoupling control on active and reactive powers. Further the response of constant DC link voltage, grid current, active power flows in the grid and reactive power exchanged between DPGS and utility grid are discussed here. Harmonic spectrum of grid current satisfies the IEEE 519-1992 standard. The reactive power flowing grid is zero and active power flowing into grid at almost unity power

factor. Output line voltage of the inverter has pure sinusoidal which ensures that grid is synchronized with DPGS. The power quality issues like power factor, harmonics reduction are improved by the proposed control technique.

REFERENCES

1. F.Blaabjerg, Zhe Chen, and S.B. Kjaer. "Power electronics as efficient interface in dispersed power generation systems", *EE Transactions on Power Electronics*, 184–1194, Sept. 2004.
2. T.Hornik and Q.C.Zhong, "Control of grid-connected DC-AC Converters in Distributed Generation: Experimental comparison of different schemes", *Proc. of IEEE 6th International Conference-Workshop on Compatibility and Power Electronics CPE 2009.Spain*.pp.271-278.
3. R.Ottersten, J.Svensson. "Vector current controlled voltage source converter-dead band control and saturation strategies", *IEEE Trans. On Power Electronics*, vol. 17, no. 2, pp. 279–285, Mar. 2002.
4. Mats AlakÅula and John-Eric Persson, "Vector controlled AC/AC converters with a minimum of energy storage," in *Proc. IEE Fifth International Conference on Power Electronics and Variable-Speed Drives*, London, UK, Oct. 26-28 1994, vol. 1, and pp. 236/239.
5. Iov F., Teodorescu R., Blaabjerg F., Andresen B., Birk J., Miranda.J., "Grid Code Compliance of Grid-Side Converter in Wind Turbine Systems", *IEEE 37th Power Electronics Specialists Conference, June 2006*, 7 pages.
6. J.S. Siva Prasad, Tushar Bhavsar, Rajesh Ghosh and G.Narayanan, "Vector Control of Three-phase AC/DC Front-End Converter", *IISc Journal Sadhana* Vol. 33, Part 5, Oct. 2008, pp. 591–613.
7. M.P.Kazmierkowaski, L.Malesani: "PWM Current Control Techniques of voltage source converters-A Survey" *IEEE. Trans. On Industrial Electronics*, Vol.45, no.5, oct.1998.
8. B.T.Ooi, X.Wang. "Voltage angle lock loop control of the boost type PWM converter for HVDC applications", *IEEE Transaction on Power Electronics*, Volume 5, No.2, pp. 229-235 April 1990.
9. B.Vasantha Reddy, B Chitti Babu " Hysteresis Controller & Delta Modulator-A Two viable scheme for Current Controlled Voltage Source Inverter", *Proceedings of IEEE International Conference on Technical Postgraduates TECHPOS 2009, Malaysia*, pp.01-05.
10. T.Thomas G. Habetler and M.D.Divan, "Performance characterization of a new discrete pulse modulated current regulator" *IEEE Transaction on Industrial applications* 1998.