

# Transmission Rate Prediction for Cognitive Radio Using Adaptive Neural Fuzzy Inference System

Shrishail Hiremath  
Dept.of ECE, NIT Rourkela  
setshri@gmail.com

Prof.Sarat Kumar Patra, Senior Member IEEE  
Dept.of ECE, NIT Rourkela  
skpatra@nitrrkl.ac.in

**Abstract**—Advances in applications demanding high data rate wireless applications and existing wireless system upgrading has lead to scarcity in spectrum. Unlicensed new technologies like Digital video broadcast (DVB), Digital audio broadcast (DAB), internet, WiMAX etc. launched recently are reaching thousands of customers at rapid speed. Most of the primary spectrum is assigned, so it is becoming very difficult to find spectrum for either new services or expanding existing infrastructure. Present government policies do not allow unlicensed access of licensed spectrum, constraining them instead to heavily populated, interference-prone frequency bands. Cognitive Radio systems promise to handle this situation by utilizing intelligent software packages that enrich their transceiver with radio-awareness, adaptability and capability to learn. In this paper, we present the working of the fifth generation intelligent radio that is Cognitive Radio (CR) system which works on predictive data rate and propose ANFIS based learning scheme to introduce intelligence in it. The performance of this is seen to be comparable to neural network based scheme with reduced complexity.

**Keywords**—Cognitive radio, spectrum hole, cognition cycle, ANFIS

## I. INTRODUCTION

Electromagnetic radio spectrum is a natural resource; the use of it by transmitters and receivers (transceivers) is licensed by government agencies. In spite of high licensing fees this resource is presently underutilized. In particular, if we were to scan the radio spectrum, including the revenue-rich urban areas, we would find that some frequency bands in the spectrum are unoccupied for some of the time, and many frequency bands are partially occupied, whereas the remaining frequency bands are heavily used [1]. It is therefore not surprising to find that underutilization of the radio spectrum is being Challenged on many fronts, including Federal Communications Commission (FCC) in the United States, TRAI of India. Cognitive radio offers a novel way to solving spectrum underutilization problems. It does this by sensing the radio environment with a twofold objective: (i) identifying those sub bands of the radio spectrum that are underutilized by the primary (i.e., legacy) users and (ii) providing the means for making those bands available for use by unserved secondary users.

With an aim to achieve above ability, cognitive radio behave in reactive or proactive manner based on external

environmental information', as well as their goals, principles, capabilities, experience and knowledge. In this regard future radio would be intelligent enough in selecting radio configuration, by taking in account of device operation status and environmental conditions, goals, policies, profiles and machine learning. In more general sense, the term radio configuration or simply configuration refers to a chosen carrier frequency and a specific [2] *radio access technology* (RAT) but can be extended to include other operating parameters like transmit power, modulation type, etc.

There are many learning techniques. In this paper we propose ANFIS based learning scheme for cognitive radio. The performance of the ANFIS assisted CR is compared with ANN based learning [2].

Following this introduction the remaining part of the paper is organized as under. Section II, provides an overview of cognitive radio. Section III, describes overview of ANFIS and its architecture. Section IV presents the simulation model for data rate prediction. Results and discussion is presented in section V.

## II. AN OVERVIEW OF COGNITIVE RADIO

The term Cognitive Radio was first defined by Joseph Mitola in year 1999 [3] as “the point in which wireless personal digital assistants (PDAs) and the related networks are sufficiently computationally intelligent about radio resources. It relates computer-to-computer communications to: (a) detect user communications needs as a function of use context, and (b) to provide radio resources and wireless services most appropriate to those needs.” Cognitive radio technology is the key technology that enables a next generation network to use spectrum in a dynamic manner. The term, cognitive radio, is formally defined as [1]: A “Cognitive is an intelligent wireless communication system that is aware of its surrounding environment (i.e., outside world), and uses the methodology of understanding-by-building to learn from the environment and adapt its internal states to statistical variations in the incoming RF stimuli by making corresponding changes in certain operating parameters (e.g., transmit-power, carrier-frequency, and modulation strategy) in real-time, with two primary objectives in mind:

- Highly reliable communications whenever and wherever needed.
- Efficient utilization of the radio spectrum.

From above definition cognitive capability includes following keywords: awareness, intelligence, learning, adaptively, reliability, and efficiency. Reconfigurability capability is provided to CR by a platform known as **software-defined radio**, upon which a cognitive radio is built. SDR is a convergence of technologies that is digital radio and computer software. Cognitive radio operation is analyzed using three phase configuration as shown in Figure.1 [2]. The first is *radio-scene analysis* (or *sensing* phase), during which different configurations are checked and the respective environment conditions, are sensed. The second is channel estimation and predictive modeling, during which potentialities of configurations are identified (discovery process) and accordingly assessed, based on the measurements of the previous phase; moreover, past experience and knowledge can be exploited in this phase. The third is configuration selection, during which the transmitter sends the desired signal by means of the “best” radio configuration (RAT, frequency, modulation, transmit power, etc.), as it derives from the information of the previous two phases [2].

Cognitive radios are capable of learning lessons and storing them into a knowledge base, from where they may be retrieved, when needed, to assist future decisions and action.

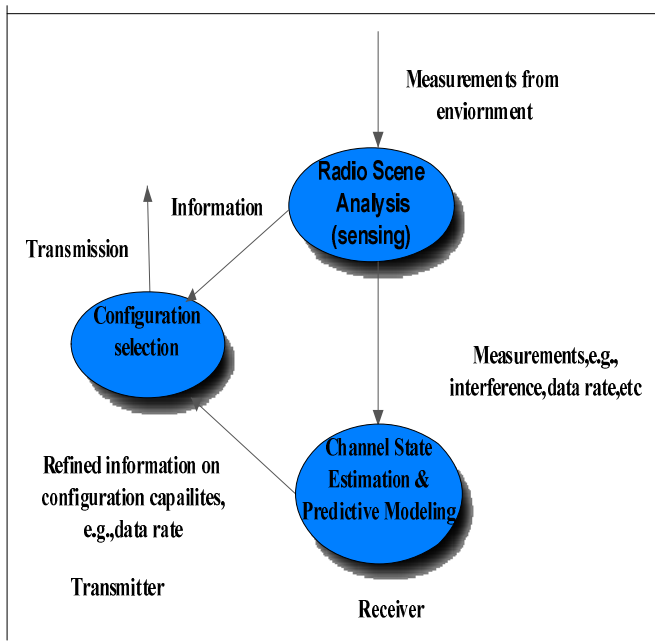

Figure.1 Cognitive radio cycle.

The cognitive radio concept was first introduced in [3], where the main focus was on the radio knowledge representation language (RKRL) and how the cognitive radio can enhance the flexibility of personal wireless services. The ultimate

objective of the cognitive radio is to obtain the best available spectrum through cognitive capability and reconfigurability as described before. Since most of the spectrum is already assigned, the most important challenge is to share the licensed spectrum without interfering with the transmission of other licensed users as illustrated in Figure.2. The cognitive radio enables the usage of temporally unused spectrum, which is referred to as **spectrum hole** or **white space** [1]. If this band is further used by a licensed user, the cognitive radio moves to another spectrum hole or stays in the same band, altering its transmission power level or modulation scheme to avoid interference[4-5].

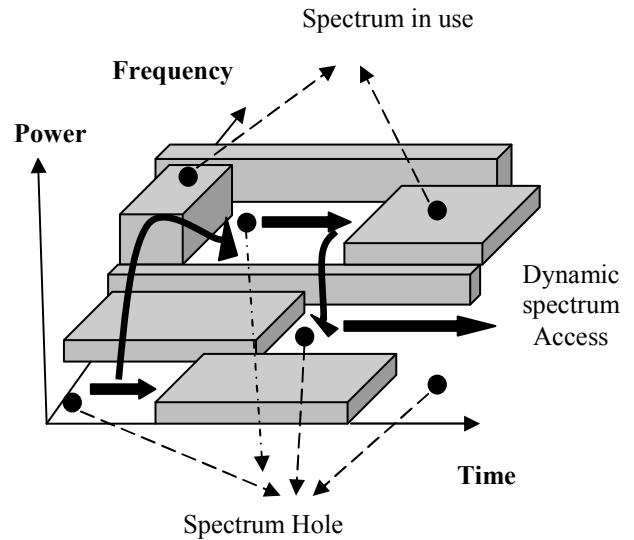

Figure.2. Spectrum hole concept.

### III. ANFIS OVERVIEW

ANFIS stands for Adaptive Neural Fuzzy Inference System. It combines best features of neural network and Fuzzy system. Fuzzy set theory plays an important role in dealing with uncertainty when making decisions in information theory applications. Therefore, fuzzy sets have attracted the growing attention and interest in modern information technology, production technique, decision making, pattern recognition, diagnostics, data analysis, etc. [6-7]. Neuro-fuzzy systems are fuzzy systems which use artificial neural networks (ANNs). Neuro-fuzzy systems harness the power of the two paradigms: fuzzy logic and ANNs, by utilizing the mathematical properties of ANNs in tuning rule-based fuzzy systems that approximate the way humans process information. Specific approach in neuro-fuzzy development is the adaptive neuro-fuzzy inference system (ANFIS), which has shown significant results in modeling nonlinear functions. In ANFIS, the membership function parameters are extracted from a data set that describes the system behavior. The ANFIS learns features in the data set and adjusts the system parameters according to a given error criterion [6].

#### a. ARCHITECTURE OF ANFIS [6]

The ANFIS is a Sugeno fuzzy model put in the framework of adaptive systems to facilitate learning and adaptation [6]. Such framework makes the ANFIS modeling more systematic and less reliant on expert knowledge. To present the ANFIS architecture, a first-order Sugeno model fuzzy system with two IF-THEN rules is considered:

Rule 1:

IF (x is  $A_1$ ) and (y is  $B_1$ ) THEN ( $f_1 = p_1 x + q_1 y + r_1$ )

Rule 2:

IF (x is  $A_2$ ) and (y is  $B_2$ ) THEN ( $f_2 = p_2 x + q_2 y + r_2$ )

where  $x$  and  $y$  are the inputs,  $A_i$  and  $B_i$  are the fuzzy sets,  $f_i$  are the outputs within the fuzzy region specified by the fuzzy rule,  $p_i$ ,  $q_i$  and  $r_i$  are the design parameters that are determined during the training process. The ANFIS architecture to implement these two rules is shown in Figure.3, where a circle is used to indicate a fixed node, and a square indicate an adaptive node.

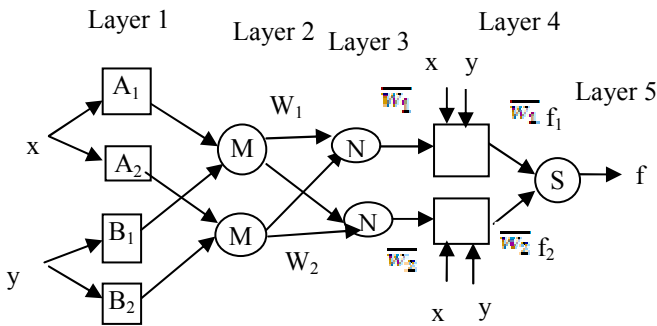

Figure.3 ANFIS architecture

In the first layer, all the nodes are adaptive nodes. The outputs of layer 1 are the fuzzy membership grade of the inputs, which are given by

$$O_i^1 = \mu_{A_i}(x) \quad i=1, 2 \quad (2)$$

$$O_i^1 = \mu_{B_{i-2}}(y) \quad i=3, 4 \quad (3)$$

Where  $\mu_{A_i}(x)$  and  $\mu_{B_{i-2}}(y)$  can adopt any fuzzy membership function. For example, if the bell-shaped memberships function is employed,  $\mu_{A_i}(x)$  given by

$$\mu_{A_i} = \frac{1}{1 + \left( \left( \frac{x - c_i}{a_i} \right)^2 \right)^{b_i}} \quad (4)$$

where  $a_i$ ,  $b_i$  and  $c_i$  are the parameters of the membership function, governing the bell-shaped functions accordingly. In the second layer, the nodes are fixed nodes. They are labeled with  $M$ , indicating that they perform as a simple multiplier. The outputs of this layer can be represented as

$$O_i^2 = w_i = \mu_{A_i}(x) \mu_{B_i}(y), \quad i=1, 2 \quad (5)$$

which are the so-called firing strengths of the rules. In the third layer, the nodes are also fixed nodes. They are labeled

with  $N$ , indicating that they play a normalization role to the firing strengths from the previous layer. The outputs of this layer can be represented as

$$O_i^3 = \bar{w}_i = \frac{w_i}{w_1 + w_2}, \quad i=1, 2 \quad (6)$$

In the fourth layer, the nodes are adaptive nodes. The output of each node in this layer is simply the product of the normalized firing strength and a first-order polynomial (for a first-order Sugeno model). Thus, the outputs of this layer are given by

$$O_i^4 = \bar{w}_i f_i = \bar{w}_i (p_i x + q_i y + r_i) \quad i=1, 2 \quad (7)$$

In the fifth layer, there is only one single fixed node labeled with  $S$ . This node performs the summation of all incoming signals. Hence, the overall output of the model is given by

$$O^5 = \sum_{i=1}^2 \bar{w}_i f_i = \frac{(\bar{w}_1 f_1 + \bar{w}_2 f_2)}{w_1 + w_2} \quad (8)$$

It can be observed that there are two adaptive layers in this ANFIS architecture, namely the first layer and the fourth layer. In the first layer, there are three modifiable parameters  $\{a_i, b_i, c_i\}$  which are related to the input membership functions. These parameters are the so-called premise parameters. In the fourth layer, there are also three modifiable parameters  $\{p_i, q_i, r_i\}$  pertaining to the first-order polynomial. These parameters are the so-called consequent parameters [6]. The task of the learning algorithm for this architecture is to tune all the modifiable parameters, namely  $\{a_i, b_i, c_i\}$  and  $\{p_i, q_i, r_i\}$  to make the ANFIS output match the training data. Details of learning for different parameters used here can be found in [6].

#### IV. SIMULATION MODEL.

Preparation procedure:

We assume that our ANFIS based scheme is tuned to arbitrary radio configuration e.g. WLAN 802.11a/g and its capabilities need to be discovered. The ANFIS based scheme is to predict data rate that is obtained by the configuration being under investigation. We follow the algorithm presented in [2], to prepare input and target value.

It is well known that WLAN using 802.11a/g operates at data rates of 6, 12, 24, 36, 48, 54 Mbps. We consider them as reference data rate and quantize whole data series in the range of above. We consider smoothing factor for exponentially moving algorithm is same as in [2] that is 0.181. A time series is randomly generated with following probability distribution [6, 12, 24, 36, 48, 54: .5 .2 .1 .1 .07 .03]. Here lowest data rate is assigned, highest probability of occurrence and highest data rate is assigned lowest probability of occurrence. Since availability of a spectral hole is more probable for lower data rates.

The simulation studies have been conducted under MATLAB environment. We compared our result with neural net

simulation of [5], when data rate for whole day is considered. The ANFIS structure we provide five simultaneous inputs at juncture. Considering time window of five as proposed in [2], we have simulation model as in Figure.4. Conventional ANFIS uses grid partition method to generate FIS. For instance, for a fuzzy inference system with 10 inputs, each with two membership functions, the grid partitioning leads to 1024 ( $=2^{10}$ ) rules, which is inhibitive large for any practical learning methods. This is termed "curse of dimensionality" refers to such situation where the number of fuzzy rules, when the grid partitioning is used, increases exponentially with the number of input variables. So this leads to increase of simulation time and poor results for high dimensional problem. So scatter partitioning method using Fuzzy-C means (FCM) clustering was used to generate the FIS, and fix number of rules by fixing fuzzy centers. This method overcomes the dimensionality problem. The conventional ANFIS is modeled as follows, two Gaussian shaped memberships are used for each of five input. Best condition is used for selection. In case of FCM based ANFIS, that FIS which gives optimized rules and best results are chosen. Best simulation results have been presented here.

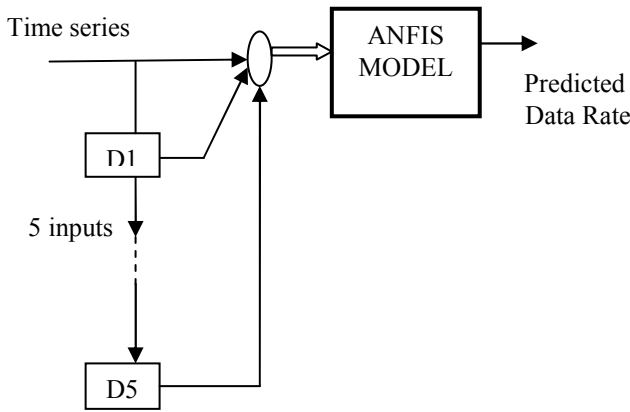

Figure.4. ANFIS model for simulation

### V. RESULTS AND DISCUSSION.

The training data set consists of 1000 data points and 100 data points are used for testing. Additional 100 data points taken for validation processes. The testing data set is taken from training set. Validation data set is unseen data. RMSE and prediction accuracy are used as performance index. Two gaussian membership functions are taken for each input. Error goal was set for 0.001. Training was for 300 epochs. It is seen prediction accuracy was 91 percentages in testing case and 89 in validation. RMSE difference between validation and testing case very small. So as compared to previously used neural network method conventional ANFIS prediction accuracy and RMSE difference are for better and that is shown in Table.1. Here number of nonlinear parameters was 20 and number linear parameters were 192 and total rules used were 32. Figure.5 (a) and (b) shows the membership

function after training and Figure.6. (a) and (b) present predicated data rate accuracy after testing and validation. Number rules are compared with weights of neural network. So total weights to be updated in case of Elman NN were 335, where as rules for conventional case is 32 which has been interpreted in Table.1. From this number parameters to be updated are very small compared to NNs method. Still rules can be reduced by using FCM to generate ANFIS. And it also overcomes dimensionality problem. By fixing number of rules or centers simulation was tested. Best results were found with 10 rules. Error goal and rules taken were same as above. RMSE difference was found to be 0.0062 and Prediction accuracy in case of testing was 86 percentage and validation case 84. Results of the best case of ANFIS-FCM are depicted in Figure.7 and Figure.8. Table.1. which shows prediction accuracy with 15 and 20 rules are for better than other but RMSE difference is more compared to other case. We also tested with previous neural network scheme of [2]. Though recurrent network has inherent capability to predict future value but as compared to ANFIS, it is not accurate in prediction. Recurrent Elman network in testing case predicted 83 data points, which is less than ANFIS. Number of epochs used to reach error goal was higher than ANFIS.

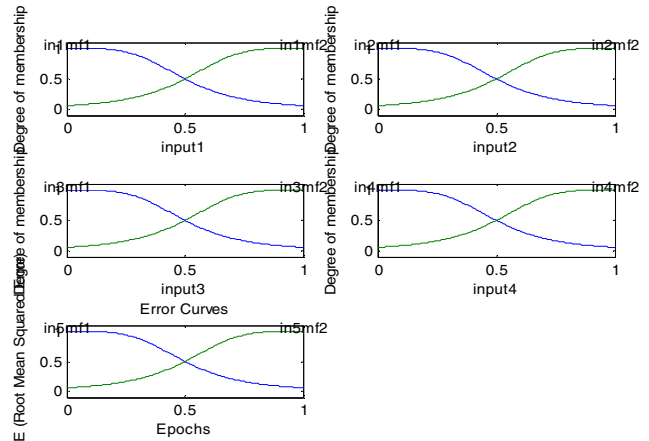

Figure.5. a) Membership function before training

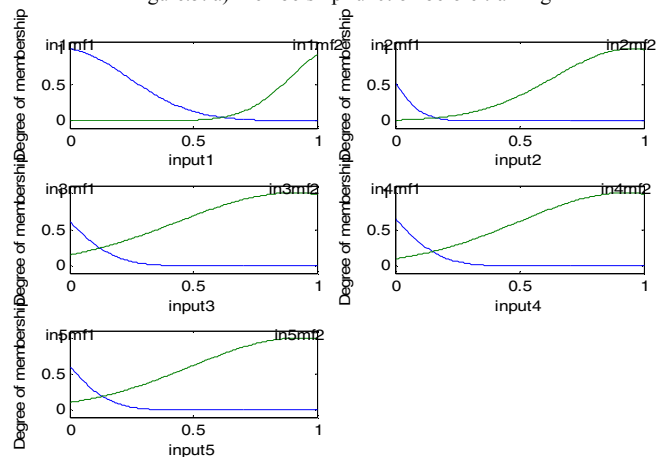

Figure.5.b) Membership function after training

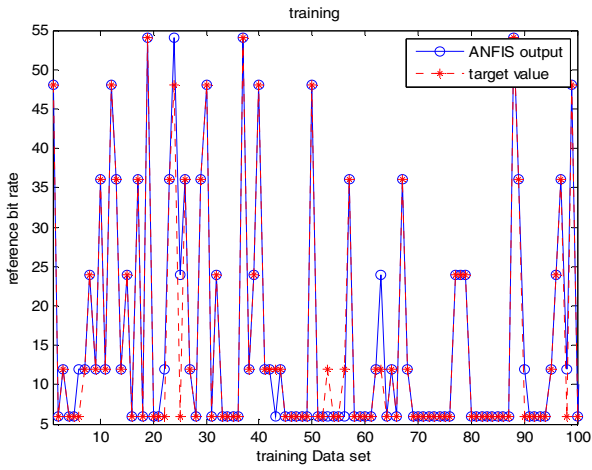

Figure.6 (a) Prediction accuracy of conventional ANFIS in testing

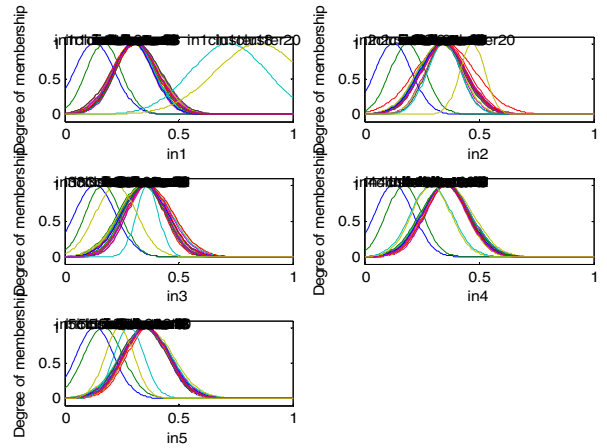

Figure.7 (b) Memberships plot for each input after training in case of FCM based structure.

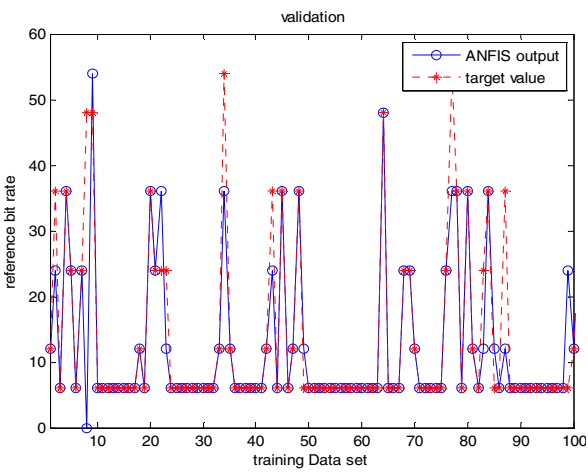

Figure.6 (b) Prediction accuracy of conventional ANFIS in validation

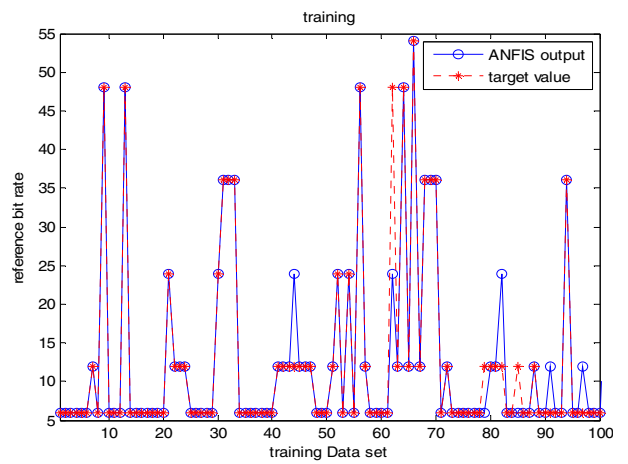

Figure.8 (a) Prediction accuracy of FCM ANFIS in testing

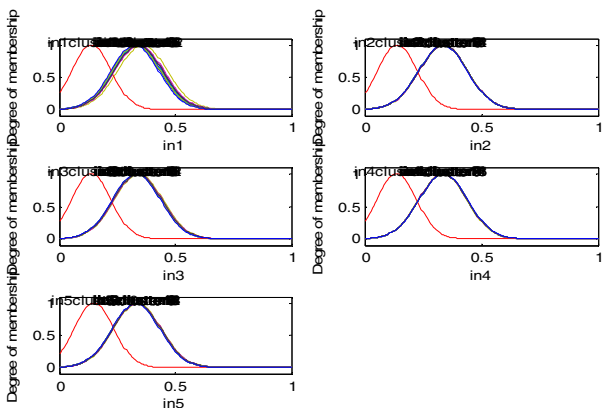

Figure.7 (a) Memberships plot for each input before training in case of FCM based structure

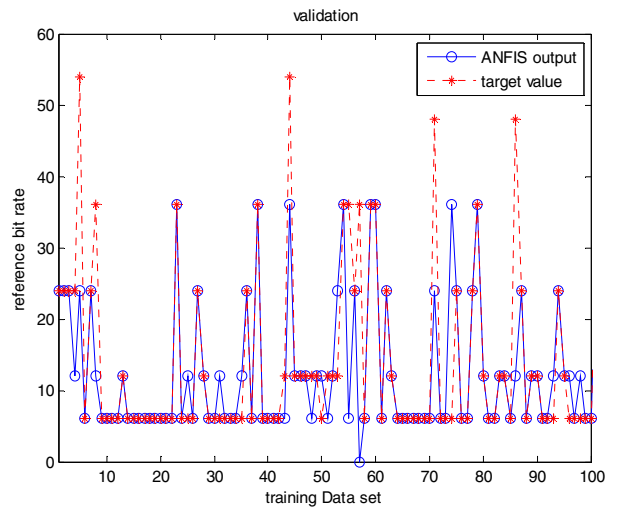

Figure.8 (b) Prediction accuracy of FCM ANFIS in validation



Table.1 Performance Index

Type of techniques used	No of Hidden nodes	Number of rules	Linear parameters	Nonlinear parameters	RMSE train	RMSE validation	RMSEtrain - RMSEval	Prediction accuracy training	Prediction accuracy validation
ANFIS grid partition	92	32	192	20	0.0518	0.0575	0.0057	91	89
ANFIS-FCM	128	10	60	100	0.0823	0.0885	0.0062	86	84
ANFIS-FCM	188	15	90	150	0.0599	0.0971	0.0372	91	83
ANFIS-FCM	248	20	120	200	0.0316	0.069	0.0374	98	91
Elman NN	15		335		0.1161	0.102	0.0141	83	81

From performance index Table.1 it can be seen ANFIS based technique are perform better in terms of prediction accuracy. Since following learning engine has to be built on SDR. ANFIS would be preferred method in terms of decision making, because ANFIS has the ability to decide like an expert system and it adapts according to changes in environmental conditions. NN method are adaptable but they are not able to make good decisions. Using clustering method, the best rules are selected for prediction.

#### VI. CONCLUSION.

Above case can be extended by considering a day divided into different time zones. Other parameters which help in improving QoS of communication links can be frame rate, modulation type, and environmental conditions etc, which help in predicting the best radio configuration. The future of wireless communication will be determined by highly varying environments with multiple RATs exhibiting diverse features. This paper discusses ANFIS based learning scheme to assist CR in predicting the data rate of particular radio configuration. As compared to neural network, our method is more accurate and involves less mathematical complexity, compared to Elman network, where the number of hidden nodes are large, thus increasing simulation complexity.

#### VII. REFERENCES

- [1] S. Haykin, "Cognitive radio: brain-empowered wireless communications," *IEEE J. Select. Areas Commun.*, vol. 23, pp. 201-220, 2005.
- [2] A. Katidiotis, P. Demestichas, K. Tsagkaris, "Neural network-based learning schemes for cognitive radio systems," *Computer Communications*, vol. 31, no. Issue 14 (September 2008), pp. 3394-3404, 2008.
- [3] J. Mitola, "Cognitive radio: an integrated agent architecture for software defined radio," Royal Institute of Technology (KTH), Stockholm, Sweden, Doctor of Technology 2000.
- [4] "FCC; ET Docket No 03-222 Notice of proposed rule making and order," December, 2003.
- [5] Ian F. Akyildiz, Won-Yeol Lee, Mehmet C. Vuran, and Shantidev Mohanty, "Next generation /dynamic spectrum access/cognitive radio wireless networks: A survey," *Computer Networks*, vol. 50, p. 2127-2159, 2006.
- [6] Roger Jang Jyh Shing, "ANFIS: Adaptive Network based Fuzzy Inference System," *IEEE Transactions on Systems, Man and Cybernetics*, vol. 23, no. 3, pp. 665-685, 1993.
- [7] E. Übeyli, "Adaptive neuro-fuzzy inference system for classification of ECG signals using Lyapunov exponents," *Computer Methods and Programs in Biomedicine*, vol. 93, no. 3, pp. 313-321, March 2009.
- [8] J. Mitola, "Cognitive radio: making software radios more personal," *IEEE Pers. Commun.*, vol. 6, no. 4, pp. 13-18, 1999.
- [9] Vijay K. Bhargava Ekram Hossain, *Cognitive Wireless Communication Networks*, 1st ed.: Springer, 2007.
- [10] P. Stavroulakis, *Neuro-Fuzzy and Fuzzy-Neural Applications in Telecommunications*, P. Stavroulakis, Ed.: Springer, 2004.
- [11] Moghram Ibrahim and Rahman Saifur, "Analysis and Evaluation of Five short-Term load forecasting Techniques," *IEEE transactions on power system*, vol. 4, pp. 1484-1491, October 1989.
- [12] Haykin Simon, *Neural Networks; A Comprehensive Foundation*, 2nd ed.: Prentice-Hall, 1999.