

# A Solar Based Power Module for Battery-Less IoT Sensors Towards Sustainable Smart Cities

Saswat Kumar Ram  
Electronics & Commu. Engineering  
NIT, Rourkela, India.  
Email: saswatram01@gmail.com

Shubham Chourasia  
Electronics & Commu. Engineering  
NIT, Rourkela, India.  
Email: shubh506@gmail.com

Banee Bandana Das  
Electronics & Commu. Engineering  
NIT, Rourkela, India  
Email: banee.bandana@gmail.com

Ayas Kanta Swain  
Electronics & Commu. Engineering  
NIT, Rourkela, India  
Email: swaina@nitrkl.ac.in

Kamalakanta Mahapatra  
Electronics & Commu. Engineering  
NIT, Rourkela, India  
Email: kkm@nitrkl.ac.in

Saraju P. Mohanty  
Computer Science and Engineering  
University of North Texas, USA.  
Email: saraju.mohanty@unt.edu

**Abstract**—This paper presents an ultra-low-power solar energy harvesting system with a power management module (SEHS-PMU) for the Internet-of-Things (IoT) applications. The voltages generated are suitable for the IoT sensors used for smart cities as well as Internet-of-Medical-Things (IoMT) based biomedical applications. The SEHS-PMU is harvesting energy from the solar cell, and it can provide regulated voltages of 3.3 V, 1.8 V, 1 V, and 0.5 V. The harvesting mechanism leads to battery-less IoT, and is safe for the humanity and environment. Charge pumps (CP) are used as a boost and buck converter, which is suitable for monolithic integration. Low drop-out regulators (LDOs) are used for regulating the loads. A digital controller controls the selection of loads as per requirement for saving the power. The SEHS-PMU is designed in CMOS 180 nm technology library.

**Index Terms**—Internet-of-Things (IoT), Sustainable IoT, Battery-Less IoT, Solar Energy, Energy Harvesting System (EHS), Power Management Unit (PMU), Low Dropout Regulator (LDO), Bandgap Reference Generator (BGR), Charge Pump

## I. INTRODUCTION

The sensors in the Internet-of-things (IoT) are used for health monitoring, environmental sensing, and remote surveillance [1]. These sensors play an important role nowadays as these are now becoming an integral part of our daily lives. A smart sensor can have the capabilities of sensing, decision making, and transmitting information to the cloud. To improve the robustness of these devices, they should ON for a longer period. Failure of these devices can affect the performances of the smart city and the biomedical things, starting from the end node to cloud in IoT [2]. A continuous power supply is a must for these sensors as batteries are having a limited lifetime. The fixed batteries are having issues from disposal point as it is not safe for humanity, and its replacement cost is an additive disadvantage. Rechargeable batteries/supercapacitors are engaged by scavenging energy from natural resources [3], [4] to extend the life span of these devices. Solar power is proved to be economical and can be used for harvesting natural energy, among other available natural resources such as solar, thermoelectric, microbial, wind and piezoelectric [2], [3], [5]–[7]. The solar cell does not need any additional mechanisms

for DC attainment [8]. The sensors used in IoT needs a regulated power supply for efficient operation. A proper power conditioning is needed such that the harvested energy can be used by the IoT sensors [9]–[11]. The concept behind sustainable IoT for smart cities is depicted in Fig. 1.

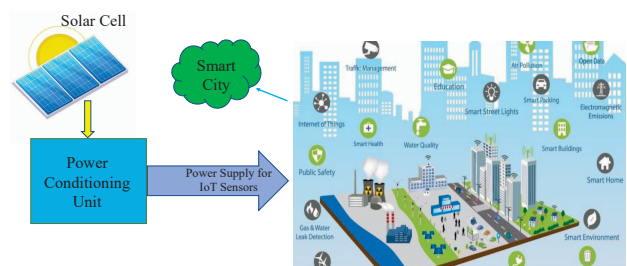

Fig. 1: Sustainable IoT in Smart Cities

The recent development in fabrication technologies and scaling down of MOSFETs increases the use of tiny devices that includes sensors used in smart cities and wearable in biomedical applications [3], [12]. These devices perform under ultra-low-power regime.

In this research work, we present a solar energy harvesting system with a power management module (SEHS-PMU) implemented in 180 nm technology that harvests the energy from the solar cell and supply to the sensors used for IoT applications in smart cities and for biomedical applications as wearable. The energy harvesting module consists of charge pumps as buck and boosts converter for stepping up and down the input voltage along with the supercapacitors for storage, and the power management unit (PMU) consists of low drop-out regulators for regulating the supply at load. The PMU also consists of start-up controller [9], [13]. The switched capacitors called as charge pumps [14] are widely used for monolithic integration.

In this paper, Section I is the introduction. Section II presents the contribution of this paper. Section III presents the

related prior research work. Section IV is the proposed system architecture that describes the energy harvesting mechanism. Section V describes the power management unit of SEHS-PMU. Section VI validates the simulation results. Finally, Section VII concludes the paper with discussions on the future direction of this research.

## II. NOVEL CONTRIBUTIONS OF THE CURRENT PAPER

The IoT sensors have to ON for a longer period to gather useful information. A continuous power supply is essential for sustainable IoT which is critical for sustainable smart cities. The traditional batteries used as the power supply has a limited lifespan. The unwanted variation in load affects the circuit performance and can damage the sensor used in IoT applications. A regulation circuit is a must for load regulation. These challenges are important and need significant research and development. The uninterrupted power supply for sensors can be taken care of by using energy harvesting as an alternative for charging the supercapacitor. The load regulation can be achieved by using low dropout regulators (LDOs). Fig. 2 shows the vision of the sensor with the proposed PMU for sustainable IoT. The contribution of this research work is as follows:

- A solar cell-based energy harvesting and power management system design for sustainable IoT.
- Four different regulated power supplies of 0.5 V, 1 V, 1.8 V, and 3.3 V are generated for different sensors used in smart cities and biomedical applications.

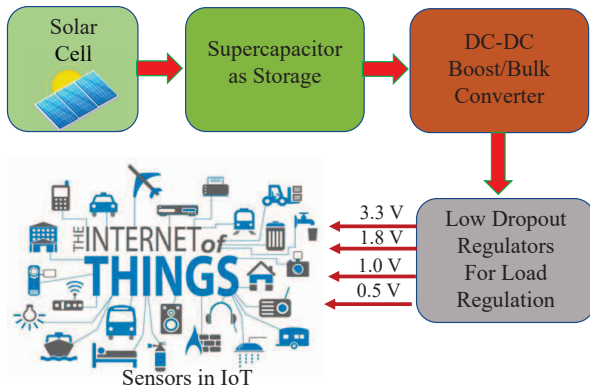

Fig. 2: Proposed PMU for sustainable IoT.

## III. RELATED PRIOR RESEARCH

Various researchers have discussed in their research about harvesting natural energy for IoT applications. Various naturally available energy sources as solar, thermometric, micro-bial, piezoelectric, and corresponding techniques to harvest these energies for powering IoT are available [2], [5]–[7], [12]. The conversion mechanisms involved in boosting the low voltage input from natural resources are available [15], [16]. In [8]–[10] various power conditioning circuits have been

presented that use the natural energy sources as input targeting the low voltage IoT applications.

Mohanty et al. in [1] describe the concept of smart cities with IoT for improving its performance. Ram et al. in [3], [12] used solar as an input for energy harvesting, and to power the IoT end node devices. In [17], [18] researchers investigated the power requirement for sensors in biomedical applications. Avalur et al. in [19] discussed the control mechanism for power management in ICs. Bediar et al. in [20] presented energy management using harvested energy from natural resources.

From the above discussion, it is found that various researchers have designed a power management unit for IoT sensors. The application domain in IoT is increasing exponentially, and new sensors are added in this chain. There is a need to design an efficient energy harvesting system with a power management unit to fulfill the increasing demand of the power-hungry sensors in IoT. This paper addresses these issues effectively for powering the sensors used in IoT for smart city applications.

## IV. PROPOSED SYSTEM ARCHITECTURE

An uninterrupted power supply is a must for sensors used in smart cities, as any information loss due to denial of supply type attack costs more than expected. The proposed SEHS-PMU designed can harvest energy from the solar cell as input with higher efficiency and can supply to different digital and analog sensors used for smart city and biomedical applications. Recently, separate regulated rails are used for supplying loads. The SEHS-PMU designed is capable of providing four different regulated outputs as 0.5 V, 1 V, 1.8 V, and 3.3 V. Fig. 3 depicts the proposed SEHS-PMU with overall system architecture. It consists of a DC-DC converter with maximum power point tracking (MPPT) [12] mechanism that boosts the solar input and harvests the energy in supercapacitor or rechargeable battery. The charge pump uses capacitors, that is suitable for monolithic integration. Many systems used in health applications as glaucoma monitoring [17] or cochlear implants [18] are volume-constrained, thereby limiting the use of passive elements like inductors in the design. Thus these applications need fully integrated, low power, low-cost management solution. The proposed EHS thus provides four power supplies with different ranges and is fully integrated.

### A. Dickson Charge Pump (DCP)

In Dickson charge pump [8], [14] the MOS devices function as diodes, so the current is unidirectional. As shown in Fig. 4, two pumping clock pulses ( $Clk$  and  $\overline{Clk}$ ) are used which are in anti-phase with an amplitude of  $V_\phi$ . The amplitude of the clock signal is the same as the supply voltage ( $V_{DD}$ ). The voltages are pumped into the circuit through the pumping capacitor  $C_1$ – $C_4$ . The voltage variation at each pumping node is expressed as described in the following expression:

$$\Delta V = V_\phi \frac{C}{C + C_s} - \frac{I_0}{f(C + C_s)}. \quad (1)$$

In the above expression,  $C$  is the capacitance of  $C_1$ – $C_4$ ,  $f$  is the clock frequency,  $C_s$  is the parasitic capacitance,  $I_0$  is the

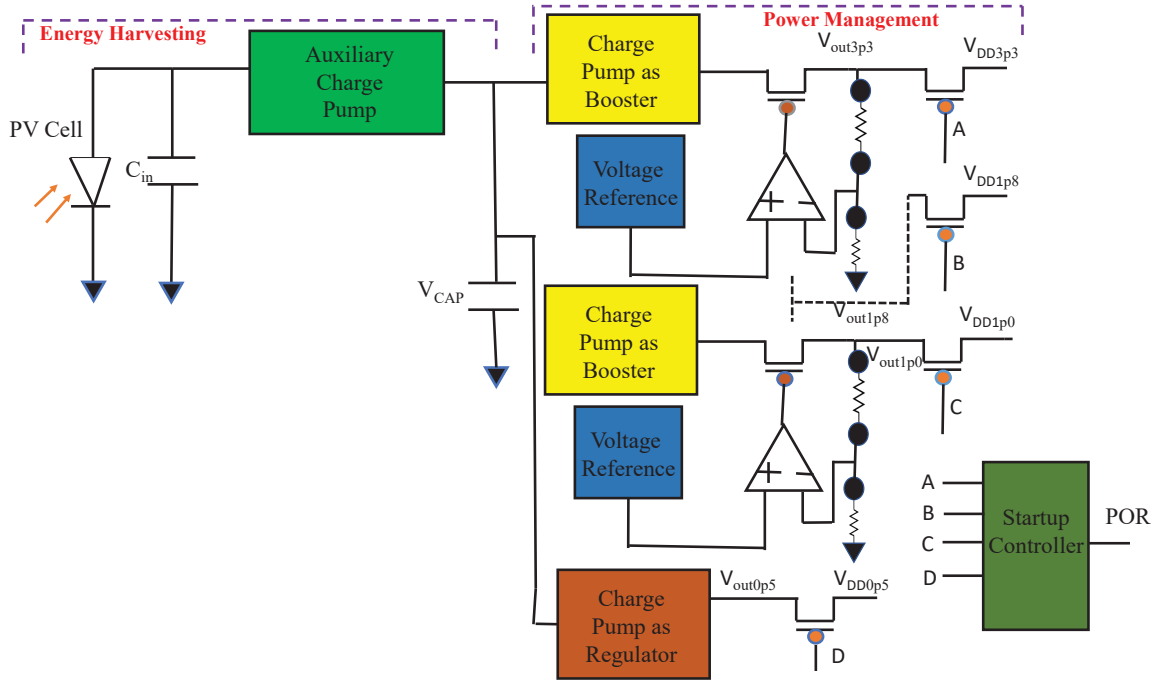

Fig. 3: Architecture of Proposed SEHS-PMU.

output current. Note that at each node the capacitor is pumped while reducing  $V_{th}$  loss.

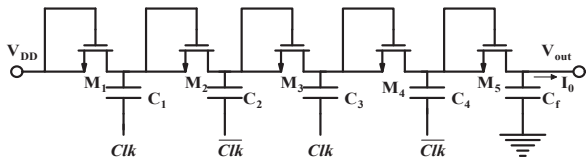

Fig. 4: Dickson Charge Pump.

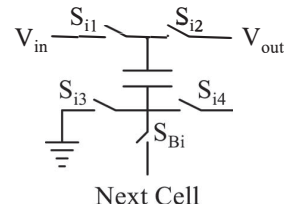

Fig. 5: Topology of a Standard Cell.

### B. Interleaved Switch Capacitor

Integrated capacitors/switches can be easily partitioned. The “Standard cell” configuration, as shown in Fig. 5 sets conversion ratio. It also requires two non-overlapping clock pulses  $Clk$  and  $\overline{Clk}$ . When  $Clk$  is High and  $\overline{Clk}$  is Low: capacitor is charged to  $(V_{in}-V_{out})$ . When  $Clk$  is Low and  $\overline{Clk}$  is High: capacitor discharges to  $V_{out}$ .  $V_{out}$  is equal to  $(V_{in}-V_{out})$ , that gives  $V_{out}=0.5 V_{in}$  as depicted in Fig. 6.

### V. PROPOSED POWER MANAGEMENT MODULE (PMU)

A continuous power supply for IoT devices is essential for the proper functioning of systems and information gathering. The energy harvested from the solar cell is stored in the supercapacitor. Proper conditioning of the stored voltage leads to efficient utilization of supply at the load end. The power should be wisely managed to get the maximum throughput. The power supply will deviate from its range when the

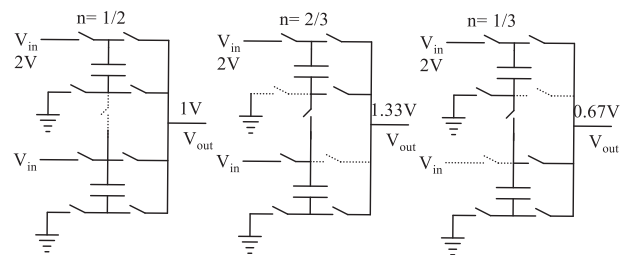

Fig. 6: Interleaving Switched Capacitor.

load varies, which may cause damages to the loads. Proper regulation is needed for efficient operation.

The energy stored in the supercapacitor is stepped up and down as per requirement using a charge pump as a DC-DC

buck/boost converters. Low dropout regulators (LDOs) are employed for load regulation and to minimize the losses. The power management unit (PMU) consists of bandgap reference generators, PMOS switches, error amplifiers, and controller.

#### A. Band gap Reference Generator (BGR)

A bandgap voltage reference is a temperature-independent voltage reference circuit widely used in integrated circuits. Circuit topology has been presented in Fig. 7. It produces a fixed (constant) voltage regardless of power supply variations, temperature changes, and circuit loading from a device. It commonly has an output voltage around 1.25 V (close to the theoretical 1.22 eV (0.195 aJ) bandgap of silicon at 0 K).

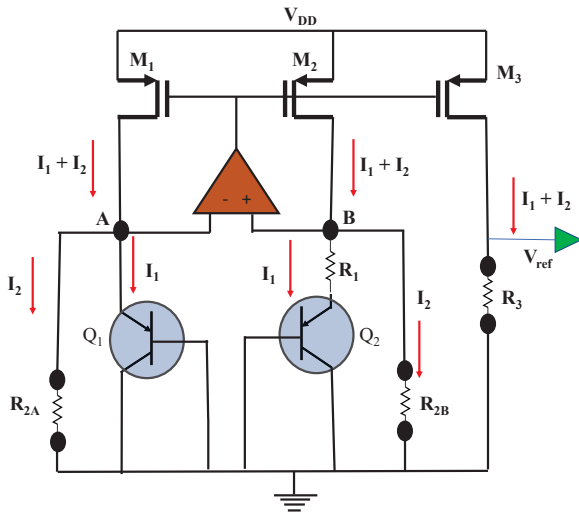

Fig. 7: Band gap Reference Generator.

The voltage difference across resistor  $R_1$  is positive temperature coefficient, so the current ( $I_1$ ) passing through  $R_1$  is considered as Proportional to Absolute Temperature (PTAT)). The voltage at node A and node B is  $V_{be}$ , which is a negative temperature coefficient, so the current ( $I_2$ ) passing through  $R_{2A}$  and  $R_{2B}$  is considered as a Complementary to Absolute Temperature (CTAT). Adding both the currents, i.e.,  $I_1 + I_2$ , a zero temperature coefficient current  $I_{ZTC}$  is obtained, which is mirrored using a current mirror circuit. By connecting a resistor  $R_3$ , the current obtained across it is  $I_{ZTC}$  and will provide a temperature-independent and power supply invariant reference voltage  $V_{ref}$ .

#### B. Low Dropout Regulator (LDO)

A low-dropout regulator (LDO) is a DC linear voltage regulator that can regulate the output voltage even when the supply voltage is very close to the output voltage. The main components are a power FET and a differential amplifier (error amplifier). One input of the differential amplifier monitors the fraction of the output determined by the resistor ratio of  $R_1$  and  $R_2$ . The second input to the differential amplifier is from

a stable voltage reference (bandgap reference). If the output voltage rises too high relative to the reference voltage, the drive to the power FET changes to maintain a constant output voltage.  $V_{out}$  depends on  $V_{ref}$ ,  $R_1$  and  $R_2$ . Changing  $R_1$  and  $R_2$  sets the output voltage.

#### C. Digital Controller

The controller has a power-on reset (POR) mechanism, and a finite state machine (FSM) is used to select the loads as per the requirement to save power [21]. The four switching signals A, B, C, and D are meant for making ON/OFF the corresponding PMOS switches, as shown in Fig. 3.

## VI. EXPERIMENTAL RESULTS

The architecture discussed in this work are designed in CMOS 180nm technology library. A solar cell is used as an input source (with temperature 27°C). The design specification is presented in Table. I.

TABLE I: Design Characterization.

BGR Generator	Error Amplifier	Converters
$I_{bias}=50\mu A$	$I_{tail}=50\mu A$	Frequency = 10 MHz
$V_{sgp}=0.7 V$	Unity Gain BW = 10 MHz	W/L Minimum
$N=4$	$0.8 < ICMR < 1.2$	$V_{CAP}=1.4 V$
$V_{ref}=0.9 V$	Slew Rate=10 V/ $\mu S$	$C_f=1pF$
$V_{DD}=1.8 V$	Phase Margin=60° and Gain=64dB	-

The two way interleaved switched capacitor is used as a step-down converter to convert the stored voltage in supercapacitor to 0.5 V, as is shown in Fig. 8.

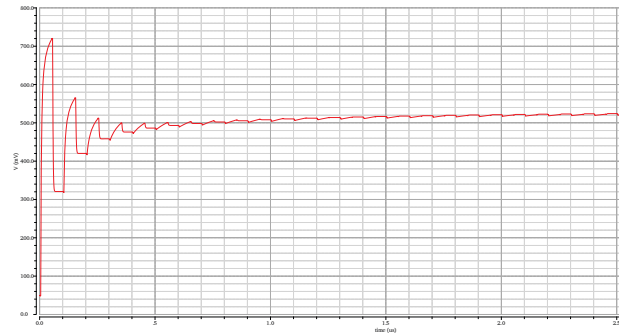
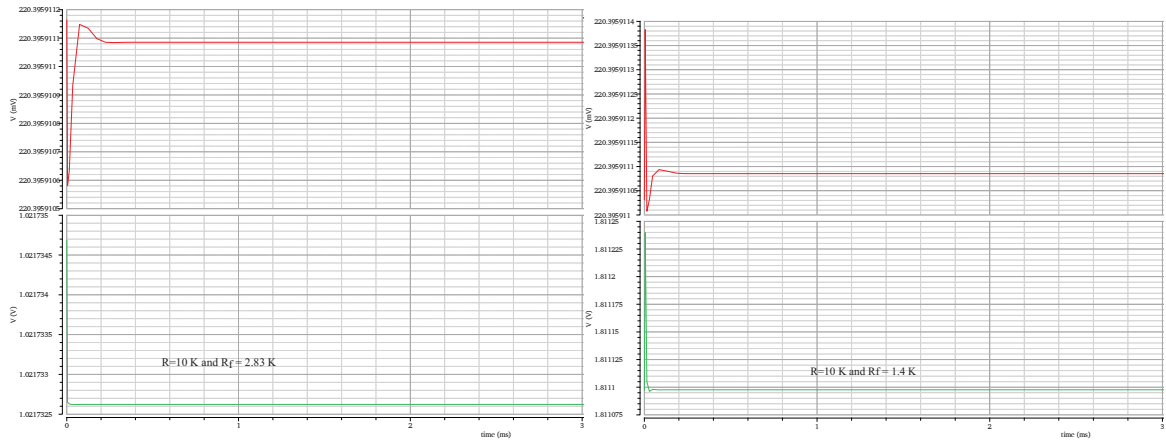

Fig. 8: Output of Two Way Interleaved Charge Pump.

The solar voltage is stepped up by using the charge pump as a DC-DC converter, and the load is regulated using the LDO, which is taking care of the supply voltage of 1 V, as depicted in Fig. 9a. The value of  $R_1$  is taken as 10 k $\Omega$ , and the feedback resistor ( $R_f$ ) is 2.83 k $\Omega$ . The bandgap reference generator is providing a reference voltage of 220 mV.

The solar voltage is stepped up by using the charge pump as a DC-DC converter, and the load is regulated using the LDO, which is taking care of a supply voltage of 1.8 V, as depicted in Fig. 9b. The value of  $R_1$  is taken as 10 k $\Omega$ , and



(a) Output of LDO  $V_{ref} = 1$  V.

(b) Output of LDO  $V_{ref} = 1.8$  V.

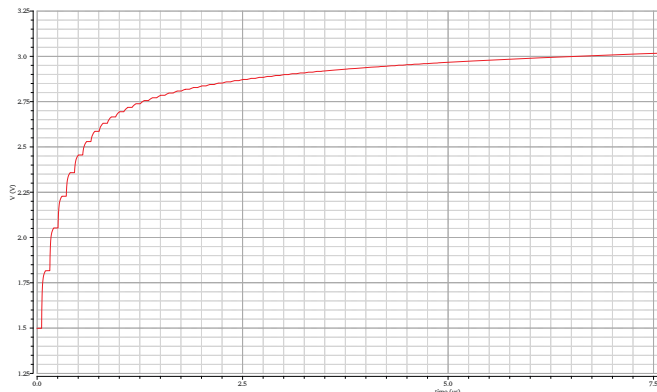

(c) Output of LDO  $V_{ref} = 3.3$  V.

Fig. 9: Simulation results of Regulated Outputs from LDOs.

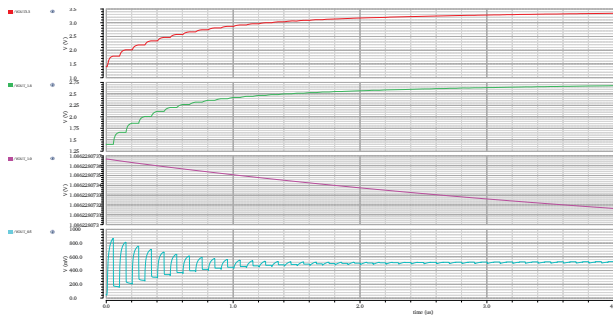

Fig. 10: Output of LDO  $V_{ref} = 3.3$  V, 1.8 V, 1 V and 0.5 V.

the feedback resistor ( $R_f$ ) is 1.4 k $\Omega$ . The bandgap reference generator is providing a reference voltage of 220 mV.

The solar voltage is stepped up by using the charge pump as a DC-DC converter, and the load is regulated using the LDO, which is taking care of the supply voltage of 3.3 V, as depicted in Fig. 9c.

The EH-PMU is providing regulated supply voltages of 0.5

V, 1 V, 1.8 V, and 3.3 V, as depicted in Fig. 10.

The SEHS-PMU is compared with the other state of art harvesters and is presented in Table. II.

## VII. CONCLUSIONS AND FUTURE DIRECTIONS

The failure of sensor nodes in the IoT scenario can be a catastrophic situation in smart cities. A continuous power requirement is a must for IoT and biomedical applications. Keeping these facts into consideration, the proposed SEHS-PMU is a self-sustainable solar EHS. It is a state of art technology towards clean energy and handling IoT edge node devices in smart cities. The resulting regulated output voltages are 0.5 V, 1 V, 1.8 V, and 3.3 V, which is the requirement of many IoT edge node devices. The proposed SEHS-PMU is consuming power within the ultra-low-power range.

The denial of service attack may cause information loss in IoT. The future directions of this research are to use the inherent features of the switched capacitors to design physically unclonable functionality (PUFs) and secure the devices used in IoT.

TABLE II: Comparison of different low energy harvesters.

Works	Feature/ Characteristics						
	Process	Source	Storage	Topology	No. of Outputs	Output Voltages	Load Power Range
Roy, et al. [9]	130nm	PV-TEG	Super-capacitor	Inductor + Super-capacitor	3	0.5 V, 1 V and 1.8 V	0-1mW@ 1 V, 0-500 $\mu$ W @0.5 V and 0-10 $\mu$ W @1.8 V
Klinefelter, et al. [11]	130nm	PV-TEG	Super-capacitor	Inductor	2	0.5 V and 1.2 V	0-5 mW
Jung, et al. [10]	180nm	Battery	Super-capacitor	-	3	0.6 v, 1.2 V and 3.3 V	20nW-500 $\mu$ W
Shih, et al. [8]	130nm	PV	Super-capacitor	-	1	1.4	0-12 $\mu$ W
<b>Current Paper</b>	180nm	PV	Super-capacitor	Super-capacitor	4	0.5 V, 1 V, 1.8 V and 3.3 V	0-1mW@ 1 V, 0-500 $\mu$ W @0.5 V, 0-10 $\mu$ W @1.8 V and 0-5 $\mu$ W @3.3 V

## ACKNOWLEDGMENTS

This research work is supported by Special Manpower Development Program for Chips to System Design (SMDP-C2SD), the Meity, Government of India.

## REFERENCES

- [1] S. P. Mohanty, U. Choppali, and E. Kougiannos, "Everything You wanted to Know about Smart Cities: The Internet of Things is the backbone," *IEEE Consumer Electronics Magazine*, vol. 5, no. 3, pp. 60–70, July 2016.
- [2] A. Omairi, Z. H. Ismail, K. A. Danapalasingam, and M. Ibrahim, "Power harvesting in wireless sensor networks and its adaptation with maximum power point tracking: Current technology and future directions," *IEEE Internet of Things Journal*, vol. 4, no. 6, pp. 2104–2115, 2017.
- [3] S. K. Ram, B. B. Das, A. K. Swain, and K. K. Mahapatra, "Ultra-Low Power Solar Energy Harvester for IoT Edge Node Devices," in *Proc. IEEE International Symposium on Smart Electronic Systems (iSES)*, 2019, pp. 205–208.
- [4] S. K. Ram, S. R. Sahoo, B. B. Das, K. mahapatra, and S. P. Mohanty, "Eternal-Thing: A Secure Aging-Aware Solar-Energy Harvester Thing for Sustainable IoT," *IEEE Transactions on Sustainable Computing*, no. 10.1109/TSUSC.2020.2987616, 2020.
- [5] J. Katic, S. Rodriguez, and A. Rusu, "A high-efficiency energy harvesting interface for implanted biofuel cell and thermal harvesters," *IEEE Transactions on Power Electronics*, vol. 33, no. 5, pp. 4125–4134, 2017.
- [6] A. Shareef, W. L. Goh, S. Narasimalu, and Y. Gao, "A Rectifier-Less AC–DC Interface Circuit for Ambient Energy Harvesting From Low-Voltage Piezoelectric Transducer Array," *IEEE Transactions on Power Electronics*, vol. 34, no. 2, pp. 1446–1457, 2019.
- [7] S. Carreon-Bautista, A. Eladawy, A. N. Mohieldin, and E. Sánchez-Sinencio, "Boost converter with dynamic input impedance matching for energy harvesting with multi-array thermoelectric generators," *IEEE Transactions on Industrial Electronics*, vol. 61, no. 10, pp. 5345–5353, 2014.
- [8] Y.-C. Shih and B. P. Otis, "An Inductorless DC–DC Converter for Energy Harvesting With a 1.2  $\mu$ W Bandgap-Referenced Output Controller," *IEEE Transactions on Circuits and Systems II: Express Briefs*, vol. 58, no. 12, pp. 832–836, 2011.
- [9] A. Roy and B. H. Calhoun, "A 71% efficient energy harvesting and power management unit for sub- $\mu$ W power biomedical applications," in *Proc. IEEE Biomedical Circuits and Systems Conference (BioCAS)*, 2017, pp. 1–4.
- [10] W. Jung, J. Gu, P. D. Myers, M. Shim, S. Jeong, K. Yang, M. Choi, Z. Foo, S. Bang, S. Oh *et al.*, "8.5 A 60%-efficiency 20nW-500 $\mu$ W tri-output fully integrated power management unit with environmental adaptation and load-proportional biasing for IoT systems," in *Proc. IEEE International Solid-State Circuits Conference (ISSCC)*, 2016, pp. 154–155.
- [11] A. Klinefelter, N. E. Roberts, Y. Shakhshsheer, P. Gonzalez, A. Shrivastava, A. Roy, K. Craig, M. Faisal, J. Boley, S. Oh *et al.*, "21.3 A 6.45  $\mu$ W self-powered IoT SoC with integrated energy-harvesting power management and ULP asymmetric radios," in *Proc. IEEE International Solid-State Circuits Conference (ISSCC)*, 2015, pp. 1–3.
- [12] S. K. Ram, S. R. Sahoo, K. Sudeendra, and K. Mahapatra, "Energy efficient ultra low power solar harvesting system design with MPPT for IoT edge node devices," in *Proc. IEEE International Symposium on Smart Electronic Systems (iSES)*, 2018, pp. 130–133.
- [13] S. K. Ram and B. B. Das, "Comparison of different control strategy of conventional and digital controller for active power line conditioner (APLC) for harmonic compensation," in *Proc. 12th International Conference on Environment and Electrical Engineering*, 2013, pp. 209–214.
- [14] Z. H. Hsieh, N. X. Huang, M. S. Shiau, H. C. Wu, S.-Y. Yang, and D. G. Liu, "A novel mixed-structure design for high-efficiency charge pump," in *Proc. 16th International Conference Mixed Design of Integrated Circuits & Systems*, 2009, pp. 210–214.
- [15] W. S. Ngueya, J. Mellier, S. Ricard, J.-M. Portal, and H. Aziza, "High voltage recycling scheme to improve power consumption of regulated charge pumps," in *Proc. 27th International Symposium on Power and Timing Modeling, Optimization and Simulation (PATMOS)*, 2017, pp. 1–5.
- [16] Z. Luo, M.-D. Ker, W.-H. Cheng, and T.-Y. Yen, "Regulated charge pump with new clocking scheme for smoothing the charging current in low voltage CMOS process," *IEEE Transactions on Circuits and Systems I: Regular Papers*, vol. 64, no. 3, pp. 528–536, 2017.
- [17] G. Chen, H. Ghaed, R.-U. Haque, M. Wiecekowski, Y. Kim, G. Kim, D. Fick, D. Kim, M. Seok, K. Wise *et al.*, "A cubic-millimeter energy-autonomous wireless intraocular pressure monitor," in *Proc. IEEE International Solid-State Circuits Conference*, 2011, pp. 310–312.
- [18] S. Bandyopadhyay, P. P. Mercier, A. C. Lysaght, K. M. Stankovic, and A. P. Chandrakasan, "A 1.1 nW energy-harvesting system with 544 pW quiescent power for next-generation implants," *IEEE Journal of Solid-State Circuits*, vol. 49, no. 12, pp. 2812–2824, 2014.
- [19] K. K. G. Avalur and S. Azeemuddin, "System Efficiency Improvement technique for Automotive Power Management IC using maximum load current selector circuit," in *Proc. 29th International Conference on VLSI Design and 2016 15th International Conference on Embedded Systems (VLSID)*, 2016, pp. 240–245.
- [20] M. Bedier, A. Karami, D. Galayko, and P. Basset, "Autonomous energy management interface for electrostatic series-parallel charge pump vibrational energy harvester," in *Proc. 15th IEEE International New Circuits and Systems Conference (NEWCAS)*, 2017, pp. 385–388.
- [21] S. K. Ram and B. B. Das, "Digital controller design for three phase active power filter for harmonic and reactive power compensation using FPGA and system generator," in *Proc. International Conference on Inventive Computation Technologies (ICICT)*, vol. 3, 2016, pp. 1–6.