

Bearing capacity of eccentrically loaded rectangular foundation on sand

Capacité portante de fondation rectangulaire excentriquement chargée sur sable

Khaled Sobhan

Florida Atlantic University, Florida, USA, ksobhan@fau.edu

Chittaranjan Patra

National Institute of Technology, Rourkela, India

Nagaratnam Sivakugan

James Cook University, Queensland, Australia

Braja Das

California State University, Sacramento, USA

ABSTRACT: Purkayastha and Char (1977) conducted a theoretical analysis for the bearing capacity of eccentrically loaded shallow strip foundation supported by sand and proposed a relationship for a reduction factor (R_k). The reduction factor is the ratio of the bearing capacity with eccentric loading to that with centric loading at the same embedment ratio (D_f/B). The reduction factor was a function of D_f/B and e/B (e = load eccentricity). It was not a function of the soil friction angle. The present study extends the concept of reduction factor to shallow rectangular foundations. To achieve that, a number of laboratory model tests on rectangular shallow foundations were conducted. The width-to-length ratio of the foundation was varied as 1.0, 0.5, 0.333, and zero, and the embedment ratio was varied as 0, 0.5, and 1.0. The load eccentricity ratios (e/B) were 0, 0.05, 0.1, and 0.15. Based on the laboratory test results, an empirical reduction factor (R_k) has been developed which is a function of e/B and B/L .

RÉSUMÉ: Purkayastha et Char (1977) ont effectué une analyse théorique de la capacité portante de bande de fondation superficielle soumise à une charge excentrique sur le sable et ont proposé une relation pour un facteur de réduction (R_k). Le facteur de réduction est le rapport de la capacité portante avec la charge excentrique par rapport à celui d'une charge centrée au même rapport d'ancrage (D_f/B). Le facteur de réduction est une fonction de D_f/B et e/B (e = charge excentricité). Il n'a pas été fonction de l'angle de frottement du sol. La présente étude étend le concept de facteur de réduction à des fondations rectangulaires superficielles. Pour y parvenir, un certain nombre d'essais de tests de laboratoire sur des fondations superficielles et rectangulaires ont été menées. Le ratio largeur-longueur de la base a été modifiée de 1.0, 0.5, 0.333, à zéro, et le rapport d'ancrage de 0, 0.5, à 1.0. Les ratios charge d'excentricité (e/B) étaient de 0, 0.05, 0.1 et 0.15. Sur la base des résultats des tests de laboratoire, un facteur de réduction empirique (R_k) a été développé, lequel est une fonction de e/B et B/L .

KEYWORDS: Bearing capacity, eccentric loading, rectangular shallow foundation, reduction factor, sand.

1 INTRODUCTION.

Shallow foundations are, on many occasions, subject to vertical eccentric loading. Meyerhof (1953) proposed the "effective area" concept to estimate the ultimate load that an eccentrically loaded shallow foundation could carry. According to this concept, for a rectangular foundations supported by a granular soil with a load eccentricity (e) in the width direction (Figure 1), the uniform load per unit "effective" area (q'_u) can be expressed as

$$q'_u = qN_q s_q d_q + \frac{1}{2} \gamma B' N_\gamma s_\gamma d_\gamma \quad (1)$$

where $q = \gamma D_f$; γ = unit weight of sand; D_f = depth of the foundation; N_q and N_γ = bearing capacity factors; s_q and s_γ = shape factors; d_q and d_γ = depth factors; B' = effective width = $B - 2e$, and B = width of foundation.

The total ultimate load (Q_u) that the foundation can carry is,

$$Q_u = q' B L \quad (2)$$

where L = length of the foundation.

Hence, the average ultimate load per unit area with eccentricity ratio e/B and embedment ratio D_f/B can be given as

$$\begin{aligned} q_{u(e/B, D_f/B)} &= \frac{Q_u}{BL} = q'_u \left(\frac{B'}{B} \right) \\ &= \frac{B'}{B} (qN_q s_q d_q + \frac{1}{2} \gamma B' N_\gamma s_\gamma d_\gamma) \end{aligned} \quad (3)$$

The ultimate bearing capacity with centric loading ($e/B=0$) at the same embedment ratio is,

$$q_{u(e/B=0, D_f/B)} = (qN_q s_q d_q + \frac{1}{2} \gamma B N_\gamma s_\gamma d_\gamma) \quad (4)$$

The ratio of $q_{u(e/B, D_f/B)}$ to $q_{u(e/B=0, D_f/B)}$ can be defined as the reduction factor R_k , or

$$R_k = \frac{q_{u(e/B, D_f/B)}}{q_{u(e/B=0, D_f/B)}} \quad (5)$$

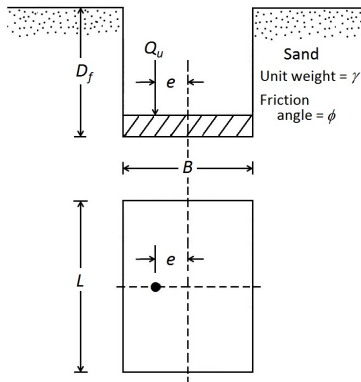

Figure 1. Eccentrically loaded foundation in sand.

Purkayasta and Char (1977), using the method of slices (Janbu 1957), theoretically determined the reduction factor for a strip foundation, which is of the form,

$$R_k = 1 - a \left(\frac{e}{B} \right)^b \quad (6)$$

where a and b are functions of D_f/B and e/B (Table 1).

It is important to note that a and b are not functions of the soil friction angle ϕ .

 Table 1. Variation of a and b (Eq. 6)

D_f/B	a	b
0.00	1.862	0.73
0.25	1.811	0.785
0.50	1.754	0.80
1.00	1.820	0.888

The purpose of the present study is to extend Eq. (6) by developing empirical relationships for the reduction factor for rectangular foundations based on laboratory model test results.

2 MODEL TESTS

Laboratory model bearing capacity tests were conducted on three model foundations in a test tank measuring 1 m (length) \times 0.65 m (width) \times 0.655 m (height). They measured 100 mm \times 100 mm ($B/L = 1$), 100 mm \times 200 mm ($B/L = 0.5$) and 100 mm \times 300 mm ($B/L = 1/3$). The fourth model foundation measured 100 mm \times 500 mm, and tests were conducted in a tank measuring 1 m \times 0.504 m \times 0.655 m. Since the width of the test tank and the length of the model foundation were approximately the same, a plane strain condition roughly existed during the tests ($\approx B/L = 0$). The model foundations were made from steel plates 30 mm thick. The bottoms of the model foundations were made rough by applying glue and then rolling the steel plates over sand.

To achieve the desired average unit weight of compaction, sand was poured into the test tank in layers of 25 mm from a fixed height using a raining technique. In order to achieve the desired density, the height of fall was fixed by making several trials in the test tank prior to the model test. The model foundation was placed at a desired D_f/B ratio at the middle of the box. Load on the model foundation was measured by a proving ring, and the corresponding settlement was measured using two dial gauges attached to the foundation diametrically opposite to each other. Other test parameters are given:

- Average unit weight of sand during test, $\gamma = 14.36$ kN/m³; relative density = 69%; friction angle, ϕ (direct shear) = 40.8° (Note: this soil at this relative density is fairly dense)
- $e/B = 0, 0.05, 0.10, 0.15$; $D_f/B = 0, 0.5, 1.0$.

3 MODEL TEST RESULTS

Based on the plots of the average load per unit area (q) vs. average settlement (s_e) (i.e., along the center line of the model foundation) that were obtained from the model tests, the ultimate bearing capacities for each test were determined, and they are shown in Col. 4 of Table 2. Column 5 of Table 2 shows the experimental variation of R_k obtained using Eq. (5).

Regression analyses for each model foundation were conducted to determine the magnitudes of a and b using (Eq. 6). The values thus obtained are given as follows:

- $B/L = 0$: $a = 2.14$; $b = 0.92$
- $B/L = 0.33$: $a = 1.68$; $b = 0.8$
- $B/L = 0.5$: $a = 1.62$; $b = 0.72$
- $B/L = 1$: $a = 1.55$; $b = 0.7$

It appears that the above values of a and b can be approximated as,

$$a = \left(\frac{B}{L} \right)^2 - 1.6 \left(\frac{B}{L} \right) + 2.13 \quad (7)$$

$$b = 0.3 \left(\frac{B}{L} \right)^2 - 0.56 \left(\frac{B}{L} \right) + 0.9 \quad (8)$$

Using the values of a and b obtained from Eqs. (7) and (8), the reduction factors of all tests have been calculated and they are shown in Col. 6 of Table 2. In addition, theoretical R_k values of all tests obtained based on the effective area method can now be calculated using Eqs. (3), (4), and (5). In doing so, the bearing capacity factors N_q and N_γ suggested respectively by Reissner (1924) and Vesic (1973) were used along with Brinch Hansen's depth factors (1970) and DeBeer's shape factors (1970). The relationships are shown at the bottom of Table 2. A comparison of the values of the reduction factors given in Cols. 5 and 7 shows fairly good agreement.

4 SCALE EFFECTS

Laboratory bearing capacity studies in sand using small-scale models are subjected to some degree of scale effects. DeBeer (1965) analyzed several model test results on square, circular, and rectangular foundations obtained from several sources. Based on this analysis, it appears that the bearing capacity factor N_γ obtained from small-scale model tests decreases rapidly with the increase in γB (i.e. with an increase in B) up to about $\gamma B = 1.5$ kN/m². For $\gamma B \geq 1.5$ kN/m², the decrease in N_γ appears to be rather small (although not completely eliminated). For the present study, γB was about 1.44 kN/m² (≈ 1.5 kN/m²).

In one of the early, but most instructive evaluations, DeBeer (1965) has shown that even large-scale field tests may yield a much different value of N_γ compared to that obtained from the theory. It was also shown, that, for loose sand, the large-scale field test results of N_γ are higher than those obtained from small-scale model footing tests in the laboratory. The reason is that the magnitude of ϕ is possibly higher due to compaction towards the end of the test rather than at the beginning. However, in the case of dense sand, N_γ obtained from field tests

Table 2. Model test results.

B/L (1)	D_f/B (2)	e/B (3)	q_u Experiment (kN/m ²) (4)	R_k Experimental (Eq. 5) (5)	R_k using predicted a and b (Eqs.7 and 8) (6)	R_k Theoretical ^a (Eqs. 3, 4 and 5) (7)	Deviation = $\frac{\text{Col.6} - \text{Col.7}}{\text{Col.6}}$ (%) (8)
0	0	0	166.67	1.00	1.00	1	0.00
0	0	0.05	133.42	0.80	0.86	0.81	-5.97
0	0	0.1	109.87	0.66	0.74	0.64	-14.94
0	0	0.15	86.33	0.52	0.62	0.49	-26.37
0	0.5	0	264.87	1.00	1.00	1	0.00
0	0.5	0.05	226.61	0.86	0.86	0.84	-1.61
0	0.5	0.1	195.22	0.74	0.74	0.70	-4.83
0	0.5	0.15	164.81	0.62	0.62	0.57	-8.43
0	1	0	353.16	1.00	1.00	1	0.00
0	1	0.05	313.92	0.89	0.86	0.86	0.43
0	1	0.1	278.6	0.79	0.74	0.73	-0.42
0	1	0.15	245.25	0.69	0.62	0.61	-1.27
0.33	0	0	131	1.00	1.00	1	0.00
0.33	0	0.05	109	0.83	0.83	0.81	-2.81
0.33	0	0.1	94	0.72	0.71	0.64	-11.68
0.33	0	0.15	71	0.54	0.61	0.49	-24.53
0.33	0.5	0	224	1.00	1.00	1	0.00
0.33	0.5	0.05	195	0.87	0.83	0.85	2.41
0.33	0.5	0.1	181	0.81	0.71	0.72	0.30
0.33	0.5	0.15	161	0.72	0.61	0.59	-3.26
0.33	1	0	336	1.00	1.00	1	0.00
0.33	1	0.05	289	0.86	0.83	0.87	4.31
0.33	1	0.1	265	0.79	0.71	0.75	4.32
0.33	1	0.15	239	0.71	0.61	0.63	3.21
0.5	0	0	128	1.00	1.00	1	0.00
0.5	0	0.05	102	0.80	0.83	0.81	-1.98
0.5	0	0.1	86	0.67	0.71	0.64	-11.16
0.5	0	0.15	68	0.53	0.61	0.49	-24.89
0.5	0.5	0	212	1.00	1.00	1	0.00
0.5	0.5	0.05	175	0.83	0.83	0.86	3.69
0.5	0.5	0.1	152	0.72	0.71	0.672	1.83
0.5	0.5	0.15	134	0.63	0.61	0.60	-1.81
0.5	1	0	327	1.00	1.00	1	0.00
0.5	1	0.05	265	0.81	0.83	0.87	5.48
0.5	1	0.1	230	0.70	0.71	0.75	5.61
0.5	1	0.15	200	0.61	0.61	0.64	4.25
1	0	0	121	1.00	1.00	1	0.00
1	0	0.05	102	0.84	0.82	0.81	-0.72
1	0	0.1	78	0.64	0.70	0.64	-9.49
1	0	0.15	67	0.55	0.60	0.49	-22.96
1	0.5	0	238	1.00	1.00	1	0.00
1	0.5	0.05	198	0.83	0.82	0.87	6.18
1	0.5	0.1	176	0.74	0.70	0.75	6.04
1	0.5	0.15	143	0.60	0.60	0.63	4.18
1	1	0	339	1.00	1.00	1	0.00
1	1	0.05	294	0.87	0.82	0.88	7.60
1	1	0.1	258	0.76	0.70	0.77	8.94
1	1	0.15	227	0.67	0.60	0.66	8.71

^a Note: For calculating Col. 7:

$$N_q = \tan^2 \left(45 + \frac{\phi}{2} \right) e^{\pi \tan \phi}$$

$$N_\gamma = 2(N_q + 1) \cot \phi$$

$$s_q = \left(1 + \frac{B}{L} \right) \tan \phi$$

$$s_\gamma = 1 - 0.4 \left(\frac{B}{L} \right)$$

$$d_q = 1 + 2 \tan \phi (1 - \sin \phi)^2 \left(\frac{D_f}{B} \right)$$

$$d_\gamma = 1$$

are smaller than those obtained from the laboratory because of the progressive nature of the failure surface developed in the soil during loading (i.e., a reduction in average ϕ value). In all cases, either field tests or laboratory tests, the N_y values are higher than those obtained theoretically. Hence, in ultimate bearing capacity estimation, it is hard to reconcile between theory, laboratory tests, and field test results. One possible reason for this discrepancy may be attributed to the use of soil friction angle obtained from plane strain tests versus those obtained from triaxial tests. Keeping this in mind, the authors believe that, since the reduction factor is a ratio of the ultimate bearing capacities, the scale effects will be minimized for all practical purposes.

5 CONCLUSIONS

Laboratory model test results for the ultimate bearing capacity of shallow rectangular foundations ($B/L = 0, 0.333, 0.5$ and 1) on sand have been reported. The tests were conducted with load eccentricity (e/B) in the width direction varying from zero to 0.15 and embedment ratio (D_f/B) varying from zero to 1 . Based on the model tests, an empirical relationship for a reduction factor (R_k) has been provided (Eqs. 6, 7 and 8). It can be seen from Table 2 that the deviations of results between those shown in Col. 6 obtained by using Eqs. 6, 7, and 8 and those shown in Col. 7 obtained by using Eqs. 3, 4, and 5 are not significant. The reduction factor is a function of e/B and B/L and, when it is multiplied by the ultimate bearing capacity of a centrally-loaded foundation, $q_{u(e/B=0, D_f/B)}$, it will provide the magnitude of $q_{u(e/B, D_f/B)}$. In the future, the study may be extended to looser sands to determine how and if the relative density of compaction affects the R_k values.

6 REFERENCES

- Brinch Hansen, J. B. 1970. *A Revised and Extended Formula for Bearing Capacity*. Bulletin 28, Danish Geotechnical Institute, Copenhagen.
- DeBeer, E. E. 1970. Experimental determination of the shape factors and bearing capacity factors of sand, *Geotechnique*, 20(4), 387-411.
- DeBeer, E.E. 1965. Bearing capacity and settlement of shallow foundations on sand. *Proceedings, Bearing Capacity and Settlement of Foundations* (Ed. A.S. Vesic), 15-33, Duke University, Durham, North Carolina, USA.
- Janbu, N. 1957. Earth pressures and bearing capacity calculations by generalized procedure of slices. *Proceedings, IV International Conference on Soil Mechanics and Foundation Engineering*, 2, 207-211, Butterworths, Oxford.
- Meyerhof, G.G. 1953. The bearing capacity of foundations under eccentric and inclined loads. *Proceedings, III International Conference on Soil Mechanics and Foundation Engineering*, Zurich, 1, 440-445.
- Purkayastha, R.D. & Char, R.A.N. 1977. Stability analysis for eccentrically loaded footings. *Journal of the Geotechnical Engineering Division*, ASCE, 103(6), 647-651.
- Reissner, H. 1924. Zum erddruckproblem. *Proceedings, First International Congress of Applied Mechanics*, Delft, 295-311.
- Vesic, A. S. 1973. Analysis of ultimate loads of shallow foundations. *Journal of the Soil Mechanics and Foundations Division*, ASCE, 99(1), 45-73.