

Dynamic Stability of Laminated Composite Curved Panels with Cutouts

S. K. Sahu¹ and P. K. Datta²

Abstract: The present investigation deals with the dynamic stability behavior of laminated composite curved panels with cutouts subjected to in-plane static and periodic compressive loads, analyzed using the finite element method. A generalized shear deformable Sanders' theory with tracers is used in this study. Numerical results obtained for vibration and buckling of composite panels with cutouts compare well with literature. The principal dynamic instability region of composite perforated panels is obtained using Bolotin's approach. The study reveals that curved panels with cutouts depict higher stiffness with the addition of curvatures. The laminated hyperbolic paraboloid panel shows the highest stiffness with the onset of instability at higher excitation frequencies. The effect of curvature in laminated composite curved panels is reduced with an increase in size of the cutout. The principal instability regions are influenced by the lamination parameters. Thus, the laminate construction, coupled with cutout geometry, can be used to the advantages of tailoring during design of composite structures for practical applications.

DOI: 10.1061/(ASCE)0733-9399(2003)129:11(1245)

CE Database subject headings: Composite materials; Dynamic stability; Finite element method; Buckling; Vibration; Panels.

Introduction

Plate and shell structures are used in a multitude of thin-walled lightweight load bearing structural parts for various modern aerospace, offshore, nuclear, automotive, and civil engineering structures. Cutouts are inevitable in structures mainly for practical considerations. Cutouts are commonly used as access ports for mechanical and electrical systems, damage inspection, altering the resonant frequency of the structures, and to serve as doors and windows. This wide range of practical applications demands a fundamental understanding of vibration, buckling, and dynamic stability characteristics. In contrast to transverse loads, panels with cutouts often lose stability at fairly low stress levels. Structures under in-plane periodic forces may undergo unstable transverse vibrations, leading to parametric resonance, due to certain combinations of the values of load parameters and natural frequency of transverse vibration. Thus, the dynamic stability of structures with cutouts is of great technical importance for understanding the behavior of dynamic systems under periodic loads.

Despite the practical importance of these structures, the number of technical papers and reports dealing with the subjects are limited due to the complexity involved. An extensive bibliography of earlier works on dynamic stability is given in review papers (Evan-iwanowski 1965; Ibrahim 1978; Simites 1987) through 1987. Most of the investigators (Cederbaum 1992; Ar-

gento and Scott 1993; Ng et al. 1998) have studied the dynamic stability of closed cylindrical shells with simply supported boundary conditions, using an analytical approach. The dynamic instability of conical shells is studied by Ganapathi et al. (1999) using a generalized differential quadrature method. The study of the parametric instability behavior of laminated composite curved panels is sparsely treated in the literature. The dynamic stability results on uniform loaded cylindrical panels are presented by Ganapathi et al. (1994). The parametric resonance characteristics of laminated composite shells subjected to nonuniform loading are studied by Sahu and Datta (2001a).

Previous investigations involving cutouts are mainly confined to free vibration and buckling of composite plates. Rajamani and Prabhakaran (1977a,b) have assumed the effect of the cutouts as equivalent to an external loading on the plate and investigated the dynamic response of thin, simply supported, and clamped laminates with circular or square cutouts. Lee et al. (1987) have predicted the natural frequencies of composite rectangular plates with cutouts, neglecting shear deformations and rotary inertia. Reddy (1982) has investigated the linear and nonlinear free vibration frequencies of isotropic, orthotropic, and laminated composite plates neglecting rotary inertia. Lee and Lim (1992) have presented the natural frequencies of isotropic and orthotropic plates with rectangular cutouts subjected to in-plane forces using Rayleigh's method. The effects of shear deformation and rotary inertia are discussed in the study by Lee et al. (1992) on natural frequencies of rectangular composite plates with cutouts. The effects of square cutouts on the natural frequencies and mode shapes of cross ply laminates are studied by Jenq et al. (1993) experimentally and using the finite element method (FEM). Sivakumar et al. (1999) have investigated the free vibration of composite plates in the presence of cutouts undergoing large amplitude oscillations using a Ritz finite element model. Chen et al. (2000) have studied the free vibration of symmetrically laminated thick doubly connected plates.

Nemeth (1988) has predicted the buckling of rectangular, symmetrically laminated angle-ply plates with central circular holes

¹Assistant Professor, Dept. of Civil Engineering, National Institute of Technology, Rourkela, India.

²Professor, Dept. of Aerospace Engineering, Indian Institute of Technology, Kharagpur, India. E-mail: pkdatta@aero.iitkgp.ernet.in

Note. Associate Editor: Dewey H. Hodges. Discussion open until April 1, 2004. Separate discussions must be submitted for individual papers. To extend the closing date by one month, a written request must be filed with the ASCE Managing Editor. The manuscript for this paper was submitted for review and possible publication on March 12, 2002; approved on April 23, 2003. This paper is part of the *Journal of Engineering Mechanics*, Vol. 129, No. 11, November 1, 2003.

using the FEM and experimental results. Lin and Kuo (1989) have studied the buckling of rectangular composite laminates with circular holes under in-plane static loading. The optimum design of the cutouts in laminated composite structures is attempted by Vellaichamy et al. (1990) using the finite element method. Srivatsa and Murty (1992) have studied critical buckling loads of laminated fiber reinforced plastic thin square panels using FEM, based on classical lamination theory. Nemeth (1996) has presented a review of works on buckling and postbuckling behavior of rectangular composite plates with cutouts. Ko (1998) has investigated the anomalous buckling characteristics of laminated metal-matrix composite plates with central square holes using the structural performance and resizing (SPAR) finite element program. The free and forced vibration of isotropic and laminated composite shells with cutouts are studied by Chakravorty et al. (1998) employing finite element methods. The influence of the cutout diameter and shape upon the buckling of square carbon fiber reinforced plastics (CFRP) panels is studied by Bailey and Wood (1996) using the ANSYS finite element code. The behavior of curved panels with cutouts subjected to in-plane periodic loads, however, is less understood. Recently, the dynamic stability of isotropic curved panel with geometrical discontinuity was investigated by Sahu and Datta (2002). The results indicate that the excitation frequency increases with the introduction of curvature from flat to curved panels with cutouts. However, the hyperbolic paraboloid with cutout shows similar instability behavior as that of a flat panel with no stiffness being added due to the curvature of the panel with cutout. The effect of curvature on instability regions is reduced for curved panels with an increase in size of the cutout.

The studies on dynamic stability of laminated composite curved panels with cutouts are not available in the literature. Such studies would shed light on the effect of anisotropy when predicting the widths of the dynamic instability region (DIR) for curved panels with cutouts. Besides this, the studies involving stability of curved panels with cutouts are difficult due to nonuniform in-plane stress distribution which alters the stresses, frequencies of vibration, buckling load, and dynamic instability regions. The dynamic stability of composite curved panels with cutouts is studied in the present investigation. The effects of size of cutout, ply orientation, static and dynamic load factors, curvature, geometry, and various boundary conditions on the instability behavior of laminated composite curved panels with cutouts are investigated.

Theory and Formulations

A laminated composite curved panel with cutout subjected to uniaxial in-plane periodic loads is considered with the coordinates x , y along the in-plane directions and z along thickness direction as shown in Fig. 1.

Governing Equations

The governing differential equations of equilibrium for free vibration of a shear deformable doubly curved panel subjected to external in-plane loading can be expressed as (Chandrasekhara 1989; Leissa and Qatu 1991)

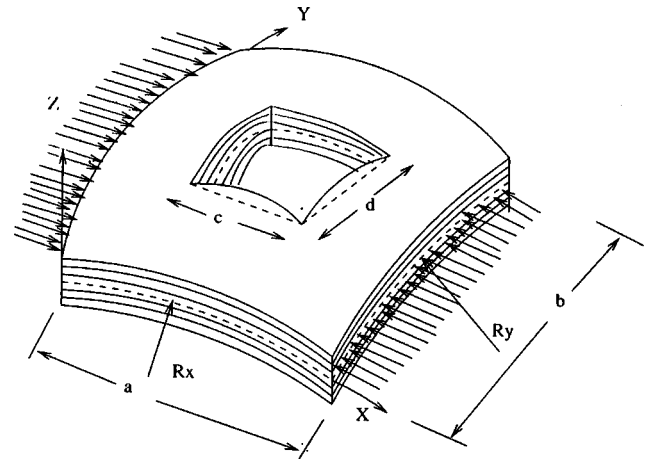

Fig. 1. Geometry and coordinate systems of curved panel with cutout

$$\left. \begin{aligned}
 \frac{\partial N_x}{\partial x} + \frac{\partial N_{xy}}{\partial y} - \frac{1}{2} C_2 \left(\frac{1}{R_y} - \frac{1}{R_x} \right) \frac{\partial M_{xy}}{\partial y} + C_1 \frac{Q_x}{R_x} + C_1 \frac{Q_y}{R_{xy}} \\
 = P_1 \frac{\partial^2 u}{\partial t^2} + P_2 \frac{\partial^2 \theta_x}{\partial t^2} \\
 \frac{\partial N_{xy}}{\partial x} + \frac{\partial N_y}{\partial y} + \frac{1}{2} C_2 \left(\frac{1}{R_y} - \frac{1}{R_x} \right) \frac{\partial M_{xy}}{\partial x} + C_1 \frac{Q_y}{R_y} + C_1 \frac{Q_x}{R_{xy}} \\
 = P_1 \frac{\partial^2 v}{\partial t^2} + P_2 \frac{\partial^2 \theta_y}{\partial t^2} \\
 \frac{\partial Q_x}{\partial x} + \frac{\partial Q_y}{\partial y} - \frac{N_x}{R_x} - \frac{N_y}{R_y} - 2 \frac{N_{xy}}{R_{xy}} + N_x^0 \frac{\partial^2 w}{\partial x^2} + N_y^0 \frac{\partial^2 w}{\partial y^2} \\
 = P_1 \frac{\partial^2 w}{\partial t^2} \\
 \frac{\partial M_x}{\partial x} + \frac{\partial M_{xy}}{\partial y} - Q_x = P_3 \frac{\partial^2 \theta_x}{\partial t^2} + P_2 \frac{\partial^2 u}{\partial t^2} \\
 \frac{\partial M_{xy}}{\partial x} + \frac{\partial M_y}{\partial y} - Q_y = P_3 \frac{\partial^2 \theta_y}{\partial t^2} + P_2 \frac{\partial^2 v}{\partial t^2}
 \end{aligned} \right\} \quad (1)$$

where N_x , N_y , and N_{xy} =in-plane stress resultants. M_x , M_y , and M_{xy} =moment resultants and Q_x , Q_y =transverse shear stress resultants.

$$(P_1, P_2, P_3) = \sum_{k=1}^n \int_{z_{k-1}}^{z_k} (\rho)_k (1, z, z^2) dz \quad (2)$$

where n =number of layers of composite curved panel; $(\rho)_k$ =mass density of k_{th} layer; and z_k =distance of k_{th} layer from midplane.

The constants R_x , R_y , and R_{xy} identify the radii of curvature in the x and y directions and the radius of twist. C_1 and C_2 are tracers by which the analysis can be carried out by shear deformable version of the theories of Sanders, Love, and Donnell's. If $C_1=C_2=1$, the equation corresponds to Sanders' theory. For the case $C_1=1$, $C_2=0$ the equation reduces to Love's theory. For $C_1=C_2=0$, the equation corresponds to Donnell's theory.

Dynamic Stability Studies

The equation of motion for a laminated composite curved panel with a cutout under in-plane loads can be expressed as

$$[M]\{\ddot{q}\} + [[K_e] - N(t)[K_g]]\{q\} = 0 \quad (3)$$

Here, $[K_e]$, $[K_g]$, and $[M]$ =global elastic stiffness, geometric stiffness, and mass matrices, respectively. $N(t)$ and q =load parameter and displacement, respectively. The in-plane loads can be periodic and may be expressed as

$$N(t) = N_s + N_t \cos \Omega t \quad (4)$$

where N_s =static portion of $N(t)$. N_t =amplitude of the dynamic portion of $N(t)$ and Ω =frequency of excitation. The stability analysis of the composite curved panels is performed expressing the periodic load in terms of the linear static buckling load N_{cr} as

$$N(t) = \alpha N_{cr} + \beta N_{cr} \cos \Omega t \quad (5)$$

where α, β =termed as static and dynamic load factors, respectively. Using Eq. (5), the equation of motion is obtained as

$$[M]\{\ddot{q}\} + [[K_e] - \alpha N_{cr}[K_g] - \beta N_{cr}[K_g] \cos \Omega t]\{q\} = 0 \quad (6)$$

Eq. (6)=Mathieu type equation, describing the instability behavior of the composite curved panel with a cutout. The dynamic instability regions (DIR) are determined (Bolotin 1964) from the boundaries of instability, which represent the periodic solution of Periods T and $2T$ where $T = 2\pi/\Omega$. The dynamic instability boundaries of Period $2T$ are of practical significance (Bolotin 1964). To obtain points on the boundaries of the dynamic instability region (DIR), the components q are written in Fourier series as

$$q = \sum_{k=1,3,5}^{\infty} \left[\{a_k\} \sin \frac{k\Omega t}{2} + \{b_k\} \cos \frac{k\Omega t}{2} \right] \quad (7)$$

These expressions are substituted into Eq. (6) and the coefficients of each sine and cosine terms are set equal to zero. The determinants are infinite and belong to a class of converging determinants. The first term solutions are sufficiently accurate for all practical purposes (Bolotin 1964). For nontrivial solutions, the determinants of the coefficients of these groups of equations are equal to zero. The equation becomes

$$\left[[K_e] - \alpha N_{cr}[K_g] \pm \frac{1}{2} \beta N_{cr}[K_g] - \frac{\Omega^2}{4} [M] \right] \{q\} = 0 \quad (8)$$

This leads to the generalized eigenvalue problem of the systems. For a given value of α the variation of the eigenvalues Ω with respect to β can be found out. The plot of such variation in the $\beta - \Omega$ plane shows the instability region associated with the laminated composite curved panel with a cutout subjected to harmonically excited in-plane load.

Finite Element Formulation

A finite element analysis is performed using a eight-noded isoparametric shell element which can accommodate laminated materials and transverse shear deformations. The element has five degrees of freedom ($u, v, w, \theta_x, \theta_y$) per node, and based on first-order shear deformation theory, where u, v, w are the displacement components in x, y , and z directions and θ_x, θ_y are rotations.

Strain Displacement Relations

Green-Lagrange's strain displacement is used throughout the structural analysis. Assuming that the material response is linear, the linear part of the strain is used to derive the elastic stiffness matrix and the nonlinear part of the strain is used to derive the geometrical stiffness matrix.

$$\{\varepsilon\} = \{\varepsilon_{ij}\} + \{\varepsilon_{nl}\} \quad (9)$$

The linear strain displacement relations are (Sahu and Datta 2001b)

$$\begin{aligned} \varepsilon_{xl} &= \frac{\partial u}{\partial x} + \frac{w}{R_x} + z\kappa_x \\ \varepsilon_{yl} &= \frac{\partial v}{\partial y} + \frac{w}{R_y} + z\kappa_y \\ \gamma_{xy} &= \frac{\partial u}{\partial y} + \frac{\partial v}{\partial x} + \frac{2w}{R_{xy}} + z\kappa_{xy} \\ \gamma_{xz} &= \frac{\partial w}{\partial x} + \theta_x - C_1 \frac{u}{R_x} - C_1 \frac{v}{R_{xy}} \\ \gamma_{yz} &= \frac{\partial w}{\partial y} + \theta_y - C_1 \frac{v}{R_y} - C_1 \frac{u}{R_{xy}} \end{aligned} \quad (10)$$

where, the bending strains κ_j are expressed as

$$\begin{aligned} \kappa_x &= \frac{\partial \theta_x}{\partial x}, \quad \kappa_y = \frac{\partial \theta_y}{\partial y} \\ \kappa_{xy} &= \frac{\partial \theta_x}{\partial y} + \frac{\partial \theta_y}{\partial x} + \frac{1}{2} C_2 \left(\frac{1}{R_y} - \frac{1}{R_x} \right) \left(\frac{\partial v}{\partial x} - \frac{\partial u}{\partial y} \right) \end{aligned} \quad (11)$$

and C_1 and C_2 =tracers by which the analysis can be reduced to that of shear deformable theories of Love and Donnell. The element geometric stiffness matrix for the curved panel is derived using the nonlinear in-plane Green's strains with curvature component as per Sanders' nonlinear theory of shells.

The nonlinear strain components are as follows:

$$\left. \begin{aligned} \varepsilon_{xnl} &= \frac{1}{2} \left(\frac{\partial u}{\partial x} \right)^2 + \frac{1}{2} \left(\frac{\partial v}{\partial x} \right)^2 + \frac{1}{2} \left(\frac{\partial w}{\partial x} - \frac{u}{R_x} \right)^2 \\ &\quad + \frac{1}{2} z^2 \left[\left(\frac{\partial \theta_x}{\partial x} \right)^2 + \left(\frac{\partial \theta_y}{\partial x} \right)^2 \right] \\ \varepsilon_{ynl} &= \frac{1}{2} \left(\frac{\partial u}{\partial y} \right)^2 + \frac{1}{2} \left(\frac{\partial v}{\partial y} \right)^2 + \frac{1}{2} \left(\frac{\partial w}{\partial y} - \frac{v}{R_y} \right)^2 \\ &\quad + \frac{1}{2} z^2 \left[\left(\frac{\partial \theta_x}{\partial y} \right)^2 + \left(\frac{\partial \theta_y}{\partial y} \right)^2 \right] \\ \gamma_{xynl} &= \frac{\partial u}{\partial x} \left(\frac{\partial u}{\partial y} \right) + \frac{\partial v}{\partial x} \left(\frac{\partial v}{\partial y} \right) + \left(\frac{\partial w}{\partial x} - \frac{u}{R_x} \right) \left(\frac{\partial w}{\partial y} - \frac{v}{R_y} \right) \\ &\quad + z^2 \left[\left(\frac{\partial \theta_x}{\partial x} \right) \left(\frac{\partial \theta_x}{\partial y} \right) + \left(\frac{\partial \theta_y}{\partial x} \right) \left(\frac{\partial \theta_y}{\partial y} \right) \right] \end{aligned} \right\} \quad (12)$$

Constitutive Relations

The laminated curved panel is considered to be composed of composite material laminae (typically thin layers). The material of each lamina consists of parallel, continuous fibers embedded in a matrix material. Each layer may be regarded on a macroscopic scale as being homogeneous and orthotropic. Assuming constant stress through the lamina, the stress resultants are related to the midplane strains and curvatures for a laminated shell element as

$$\begin{Bmatrix} N_i \\ M_i \\ Q_i \end{Bmatrix} = \begin{bmatrix} A_{ij} & B_{ij} & 0 \\ B_{ij} & D_{ij} & 0 \\ 0 & 0 & S_{ij} \end{bmatrix} \begin{Bmatrix} \varepsilon_j \\ \kappa_j \\ \gamma_m \end{Bmatrix} \quad (13)$$

or

$$\{F\} = [D]\{\varepsilon\} \quad (14)$$

The extensional, bending-stretching coupling and bending stiffnesses are expressed as

$$(A_{ij}, B_{ij}, D_{ij}) = \sum_{k=1}^n \int_{z_{k-1}}^{z_k} (\overline{Q_{ij}})_k (1, z, z^2) dz \quad i, j = 1, 2, 6 \quad (15)$$

The transverse shear stiffness is expressed as

$$S_{ij} = \sum_{k=1}^n \int_{z_{k-1}}^{z_k} \kappa (\overline{Q_{ij}})_k dz \quad i, j = 4, 5 \quad (16)$$

where κ = transverse shear correction factor.

The above off-axis stiffness values are

$$\begin{aligned} \overline{Q_{11}} &= Q_{11}m^4 + 2(Q_{12} + 2Q_{66})m^2n^2 + Q_{22}n^4 \\ \overline{Q_{12}} &= (Q_{11} + Q_{22} - 4Q_{66})m^2n^2 + Q_{12}(m^4 + n^4) \\ \overline{Q_{22}} &= Q_{11}n^4 + 2(Q_{12} + 2Q_{66})m^2n^2 + Q_{22}m^4 \\ \overline{Q_{16}} &= (Q_{11} - Q_{12} - 2Q_{66})nm^3 + (Q_{12} - Q_{22} + 2Q_{66})n^3m \\ \overline{Q_{26}} &= (Q_{11} - Q_{12} - 2Q_{66})mn^3 + (Q_{12} - Q_{22} + 2Q_{66})m^3n \\ \overline{Q_{66}} &= (Q_{11} + Q_{22} - 2Q_{12} - 2Q_{66})n^2m^2 + Q_{66}(n^4 + m^4) \end{aligned} \quad (17)$$

The elastic constant matrix corresponding to transverse shear deformation is

$$\begin{aligned} \overline{Q_{44}} &= G_{13}m^2 + G_{23}n^2 \\ \overline{Q_{45}} &= (G_{13} - G_{23})mn \\ \overline{Q_{55}} &= G_{13}n^2 + G_{23}m^2 \end{aligned} \quad (18)$$

where $m = \cos \theta$ and $n = \sin \theta$; and θ = angle between the arbitrary principal axes with the material axes in a layer. The on-axis stiffnesses are

$$\begin{aligned} Q_{11} &= \frac{E_{11}}{(1 - \nu_{12}\nu_{21})} \\ Q_{12} &= \frac{E_{11}\nu_{21}}{(1 - \nu_{12}\nu_{21})} \\ Q_{21} &= \frac{E_{22}\nu_{12}}{(1 - \nu_{12}\nu_{21})} \\ Q_{22} &= \frac{E_{22}}{(1 - \nu_{12}\nu_{21})} \\ Q_{66} &= G_{12} \end{aligned} \quad (19)$$

Element Elastic Stiffness Matrix

$$[k_e]_e = \int_{-1}^1 \int_{-1}^1 [B]^T [D] [B] J d\xi d\eta \quad (20)$$

where $[B]$ = strain-displacement matrix; $[D]$ = elasticity matrix; and J = Jacobian. Reduced integration technique is adopted to avoid possible shear locking. Consistent element mass matrix is expressed as

$$[m]_e = \int_{-1}^1 \int_{-1}^1 [N]^T [P] [N] J d\xi d\eta \quad (21)$$

where $[N]$ = shape function matrix and

$$[P] = \begin{bmatrix} P_1 & 0 & 0 & P_2 & 0 \\ 0 & P_1 & 0 & 0 & P_2 \\ 0 & 0 & P_1 & 0 & 0 \\ P_2 & 0 & 0 & P_3 & 0 \\ 0 & P_2 & 0 & 0 & P_3 \end{bmatrix} \quad (22)$$

and

$$(P_1, P_2, P_3) = \sum_{k=1}^n \int_{z_{k-1}}^{z_k} (\rho)_k (1, z, z^2) dz \quad (23)$$

Geometric Stiffness Matrix

Using the nonlinear strains, the strain energy can be written as

$$\begin{aligned} U_2 = \int_A \frac{h}{2} \left[\sigma_x^0 \left\{ \left(\frac{\partial u}{\partial x} \right)^2 + \left(\frac{\partial v}{\partial x} \right)^2 + \left(\frac{\partial w}{\partial x} - \frac{u}{R_x} \right)^2 \right\} + \sigma_y^0 \left\{ \left(\frac{\partial u}{\partial y} \right)^2 \right. \right. \\ \left. \left. + \left(\frac{\partial v}{\partial y} \right)^2 + \left(\frac{\partial w}{\partial y} - \frac{v}{R_y} \right)^2 \right\} + 2\tau_{xy}^0 \left\{ \left(\frac{\partial u}{\partial x} \frac{\partial u}{\partial y} \right) + \left(\frac{\partial v}{\partial x} \frac{\partial v}{\partial y} \right) + \left(\frac{\partial w}{\partial x} \right. \right. \right. \\ \left. \left. - \frac{u}{R_x} \right) \left(\frac{\partial w}{\partial y} - \frac{v}{R_y} \right) \right\} \right] dx dy + \int_A \frac{h^3}{24} \left[\sigma_x^0 \left\{ \left(\frac{\partial \theta_x}{\partial x} \right)^2 + \left(\frac{\partial \theta_y}{\partial x} \right)^2 \right\} \right. \\ \left. + \sigma_y^0 \left\{ \left(\frac{\partial \theta_y}{\partial y} \right)^2 + \left(\frac{\partial \theta_x}{\partial y} \right)^2 \right\} + 2\tau_{xy}^0 \left\{ \left(\frac{\partial \theta_y}{\partial x} \frac{\partial \theta_y}{\partial y} \right) \right. \right. \\ \left. \left. + \left(\frac{\partial \theta_x}{\partial x} \frac{\partial \theta_x}{\partial y} \right) \right\} \right] dx dy \end{aligned} \quad (24)$$

This can also be expressed as

$$U_2 = \frac{1}{2} \int_v [f]^T [S] [f] dv \quad (25)$$

where

$$\begin{aligned} \{f\} = \left[\frac{\partial u}{\partial x}, \frac{\partial u}{\partial y}, \frac{\partial v}{\partial x}, \frac{\partial v}{\partial y}, \left(\frac{\partial w}{\partial x} - \frac{u}{R_x} \right), \left(\frac{\partial w}{\partial y} \right. \right. \\ \left. \left. - \frac{v}{R_y} \right), \frac{\partial \theta_x}{\partial x}, \frac{\partial \theta_x}{\partial y}, \frac{\partial \theta_y}{\partial x}, \frac{\partial \theta_y}{\partial y} \right]^T \end{aligned} \quad (26)$$

and

$$[S] = \begin{bmatrix} s & 0 & 0 & 0 & 0 \\ 0 & s & 0 & 0 & 0 \\ 0 & 0 & s & 0 & 0 \\ 0 & 0 & 0 & s & 0 \\ 0 & 0 & 0 & 0 & s \end{bmatrix} \quad (27)$$

where

$$[s] = \begin{bmatrix} \sigma_x^0 & \tau_{xy}^0 \\ \tau_{xy}^0 & \sigma_y^0 \end{bmatrix} = \frac{1}{h} \begin{bmatrix} N_x^0 & N_{xy}^0 \\ N_{xy}^0 & N_y^0 \end{bmatrix} \quad (28)$$

Since the stress distribution is not uniform due to the cutout, the in-plane stress resultants N_x^0 , N_y^0 , and N_{xy}^0 , at each Gauss point are obtained separately by a plane stress analysis and the geometric stiffness matrix is formed with the stress resultants.

$$\{f\} = [G] \{\delta_e\} \quad (29)$$

where

$$\{\delta_e\} = [uvw\theta_x\theta_y]^T \quad (30)$$

Table 1. Convergence of Nondimensional Fundamental Frequencies of Simply Supported Square Plate with Cutout Size of $c/a=0.5$

Mesh division	Nondimensional frequencies		
	Isotropic	Orthotropic	Composite
8×8	23.570	51.0597	48.2535
12×12	23.4703	50.7899	48.0650
16×16	23.4364	50.6944	48.0222
20×20	23.4218	50.6505	48.0064
Reddy (1982)	(23.489)	(51.232)	(48.414)

Note: $a/b=1$, $b/h=100$. Nondimensional frequency, $\lambda = \omega a^2 \sqrt{(\rho h/D_{22})}$.

The strain energy becomes

$$U_2 = \frac{1}{2} \int_v \{\delta_e\}^T [G]^T [S] [G] \{\delta_e\} dv = \frac{1}{2} \{\delta_e\}^T [k_g]_e \{\delta_e\} \quad (31)$$

where the element geometric stiffness matrix

$$[k_g]_e = \int_{-1}^1 \int_{-1}^1 [G]^T [S] [G] d\xi d\eta \quad (32)$$

The overall matrices $[K_e]$, $[K_g]$, and $[M]$ are obtained by assembling the corresponding element matrices using the skyline technique.

Results and Discussions

The results are presented for a laminated composite flat and curved panels with different combinations of boundary conditions. Shells of various geometries such as cylindrical ($R_y/R_x=0$), spherical ($R_y/R_x=1$), and hyperbolic paraboloidal shells ($R_y/R_x=-1$) are studied. S , C , and F denote a simply supported, clamped, and free edges, respectively. The notation $SCSF$ identifies a panel with the edges $x=0$, $y=0$, $x=a$, and $y=b$ having the boundary conditions in that order. The boundary conditions are described as follows:

1. Simply supported boundary

$$S: \quad u=w=\theta_y=0 \quad \text{at } x=0, a \quad \text{and } v=w=\theta_x=0 \quad \text{at } y=0, b; \quad \text{and}$$

2. Clamped boundary

$$C: \quad u=v=w=\theta_x=\theta_y=0 \quad \text{at } x=0, a \quad \text{and } y=0, b.$$

The nondimensional excitation frequency parameters are defined as

$$\Omega = \bar{\Omega} a^2 \sqrt{\rho/E_{22}h^2}$$

where $\bar{\Omega}$ =excitation frequency in radians/second.

Convergence Study

Convergence studies are made for nondimensional fundamental frequencies of vibration of the simply supported (SSSS) square laminated composite plate with a square hole of size ratio $c/a=0.5$. As shown in Table 1, the frequencies of vibration are computed for different mesh sizes and the results are compared with the free vibration study on isotropic, orthotropic, and composite flat panels by Reddy (1982). The fundamental frequencies of vibration gradually decrease with an increase of mesh size from 8×8 to 20×20 and tend to converge at a mesh size of 20×20. The frequencies based on present formulation are comparatively lower to the results by Reddy (1982), in which the effect of rotary inertia is neglected. Based on the convergence studies, a mesh of 20×20 is employed to idealize the full panels with cutouts in the subsequent dynamic stability studies.

Comparison with Previous Studies

The accuracy and efficiency of the present formulation are established through comparison of frequency parameters of isotropic, orthotropic and composite plates ($0^\circ/90^\circ$ lamination) with different thickness ratios and modes of vibration with the finite element results of Reddy (1982), as shown in Table 2. The present results are in good agreement with the results by Reddy (1982). For verifying the accuracy of the present finite element solutions, the buckling load of a laminated composite plate with cutout are solved to compare with the results by Ko (1998), using the structural performance and resizing (SPAR) finite element program. Good agreement exists between the present finite element results with the literature as shown in Table 3. After validating the free vibration and buckling results of the laminated composite panel with a cutout, the investigation is then extended for the dynamic instability studies.

Dynamic Stability Studies

Numerical results are presented for dynamic stability studies on laminated composite curved panels with cutouts. All of the laminates are assumed to be of the same thickness and made of ortho-

Table 2. Comparison of Nondimensional Fundamental Frequencies of Simply Supported Square Plate with Cutout Size of $c/a=0.5$

a/h	Isotropic		Orthotropic		Composite	
	λ_{11}	λ_{13}	λ_{11}	λ_{13}	λ_{11}	λ_{13}
10	22.730 (22.804)	59.754 (60.205)	42.380 (42.693)	82.865 (83.451)	43.320 (43.728)	96.786 (97.379)
20	23.188 (23.240)	67.409 (68.391)	47.592 (47.934)	98.643 (100.10)	46.578 (46.971)	126.614 (128.56)
25	23.262 (23.309)	68.878 (70.032)	48.543 (48.907)	101.718 (103.43)	47.074 (47.464)	133.441 (135.85)
100	23.476 (23.489)	73.024 (75.076)	50.802 (51.232)	109.281 (112.22)	48.076 (48.414)	152.355 (156.85)

Note: Results in bracket are from Reddy (1982). $D_{22}=E_{22}h^3/12(1-\nu_{12}\nu_{21})$. Nondimensional frequency, $\lambda = \omega a^2 \sqrt{(\rho h/D_{22})}$.

Table 3. Comparison of Buckling Loads N_x in lb/in. of Square Simply Supported Panel with Cutout with $[90/0/90]_2$ Lamination

Reference	Buckling load in lb/in.							
	$c/a=0.0$	0.1	0.2	0.3	0.4	0.5	0.6	0.7
Present	50.0166	47.8651	43.5676	40.2852	38.2599	36.9991	36.1332	35.7044
Ko (1998)	49.2286	46.9455	42.8393	39.6854	37.7255	36.4901	35.6396	35.2243

Note: $a=b=20$ in., $h=0.064$ in., $E_L=27.72 \times 10^6$ lb/in.², $E_T=18.09 \times 10^6$ lb/in.², $G_{LT}=8.15 \times 10^6$ lb/in.², $\nu_{LT}=0.3$.

tropic material. The material properties considered here are of typical titanium metal matrix composite and are as follows:

$$E_L=191.13 \text{ GPa } (27.72 \times 10^6 \text{ lb/in.}^2),$$

$$E_T=124.73 \text{ GPa } (18.09 \times 10^6 \text{ lb/in.}^2),$$

$$G_{LT}=56.19 \text{ GPa } (8.15 \times 10^6 \text{ lb/in.}^2), \quad \nu_{LT}=0.3$$

The dynamic instability regions (DIR) are plotted for a flat and cylindrical composite panel with/without static component to consider the effects of static load factor, size of cutout, different panel geometries, and boundary conditions. The computed buckling load of the simply supported composite panel with dimensions $a=b=500$ mm, $h=2$ mm, and lamination properties $[45^\circ/-45^\circ/-45^\circ/45^\circ]_2$ is taken as the reference load for all further computations in line with Moorthy et al. (1990).

The effects of the size of the cutout on the instability region of a flat panel are studied from $c/a=0.0$ (no cutout) to 0.8 at an interval of 0.1. However, for clarity, the plots are shown for size of a cutout $c/a=0.0$ (no cutout) to 0.8 at an interval of 0.2 and $c/a=0.5$. The variations of the instability region versus dynamic in-plane load is shown in Fig. 2. It can be observed that the onset of instability occurs with lower excitation frequencies for small cutouts in simply supported plates up to $c/a=0.2$. With an increase of the cutout size, the onset of excitation frequency increases along with wider dynamic instability regions. The onset of instability occurs with higher excitation frequency for plates with a cutout size of $c/a=0.4$ onward than that of plate without a cutout ($c/a=0.0$). The onset of instability occurs at higher excitation frequencies up to plate with a cutout of $c/a=0.8$ with wider instability regions. This may be attributed to the reduction of mass and predominance of the boundary restraints over the entire plate. The results show that the dynamic instability behavior for composite curved panels with geometrical discontinuity is more pronounced in comparison to the corresponding isotropic cases (Sahu and Datta 2002). The effect of the static component

of load on the instability regions of the plate with a cutout of size $c/a=0.5$ is studied for $\alpha=0.0, 0.2$, and 0.4, as shown in Fig. 3. Due to an increase of compressive static in-plane load, the instability regions tend to shift to lower frequencies and become wider. Further investigations are done with a static load factor of 0.2 (unless otherwise mentioned). Studies have also been made for comparison of instability regions for different shell geometries with the introduction of curvature. The dynamic instability regions are plotted for plate and different curved panels such as cylindrical ($b/R_y=0.25$), spherical ($a/R_x=b/R_y=0.25$), and hyperbolic paraboloids ($a/R_x=-0.25, b/R_y=0.25$) with cutouts of $c/a=0.5$ and are compared in Fig. 4. It is observed that the excitation frequency increases with an introduction of curvature from laminated composite flat panels to curved panels with cutouts. The excitation frequency is higher for the cylindrical panel to that of a flat panel and still increases for a spherical panel with curvature. The onset of instability occurs later for hyperbolic paraboloid with narrow instability regions unlike the isotropic cases. Fig. 5 shows the influence of different boundaries (SSSS, SCSC, CSCS, CCCC) on the principal instability regions. As expected, the instability occurs at a higher excitation frequency from simply supported to clamped edges due to the restraint at the edges. The laminated cylindrical panels with clamped straight edges and simply supported curved boundaries show higher excitation frequencies with narrow instability regions than panels with clamped curved edges and simply supported straight edges. The effect of size of the cutout on instability regions of a simply supported cylindrical panel is investigated for $c/a=0.0, 0.2, 0.4, 0.5, 0.6$, and 0.8. In Fig. 6, as expected, the onset of instability occurs later for cylindrical panels to that of a flat plate with cutout. The onset of instability occurs earlier with an increase of size of the cutout up to $c/a=0.6$. This may be due to the effect of curvature gradually reducing the effect due to an increase in size of the cutout. With further increase of cutout size ($c/a=0.8$), the excitation

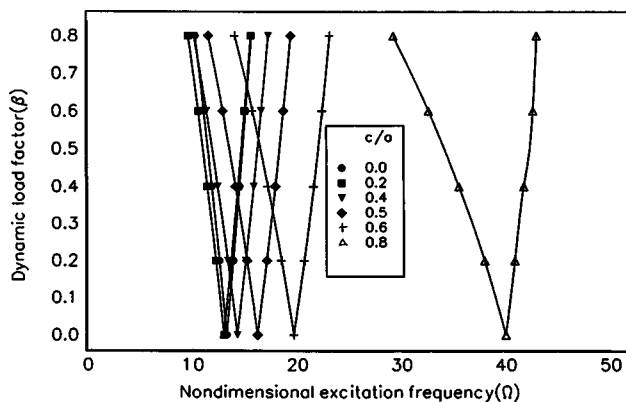

Fig. 2. Effect of size of cutout on instability region of simply supported plate for $c/a=0, 0.2, 0.4, 0.5, 0.6$, and 0.8, $a/R_x=0, b/R_y=0.0, \alpha=0.0$

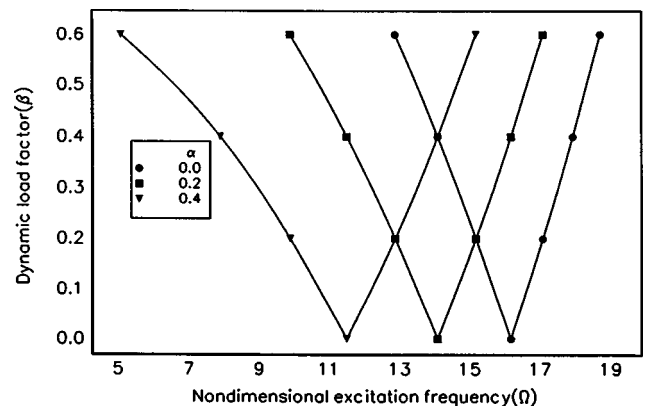

Fig. 3. Effect of static load factor on instability region of simply supported plate with cutout: $a/b=1, a/R_x=0.0, b/R_y=0.0, c/a=0.5$ for $\alpha=0.0, 0.2$, and 0.4

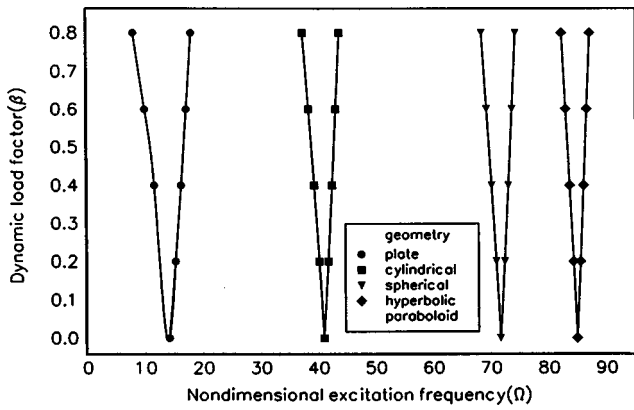

Fig. 4. Effect of cutout on instability region of different curved panels: flat panel ($a/R_x = b/R_y = 0$); cylindrical ($a/R_x = 0, b/R_y = 0.25$); spherical ($a/R_x = b/R_y = 0.25$); hyperbolic paraboloid ($a/R_x = -0.25, b/R_y = 0.25$) for $a/b = 1, c/a = 0.5$, and $\alpha = 0.2$

frequency suddenly increases having wider dynamic instability regions. The onset of instability occurs with a higher excitation frequency for the cylindrical panel with a cutout size $c/a = 0.8$ than that with $c/a = 0.6$ with very wide DIR. This is due to the fact that the curved panels with a higher size of a cutout behaves as a plate and the excitation frequency increases. The onset of instability will even occur earlier for a cylindrical panel with a cutout size of $c/a = 0.8$ for a higher value of dynamic load beyond $\beta = 0.7$. The effect of ply orientation on instability of the eight layer symmetric angle-ply curved panels with a cutout size of $c/a = 0.5$ is studied as shown in Fig. 7. The onset of instability is influenced by ply orientations. The onset of instability occurs earlier for a ply orientation of $0, 15$, and 30° . The onset of instability occurs later for $45, 60, 75$, and 90° orientations. The curved panel with a cutout shows a preferential ply orientation of 60° for this size of cutout. The instability occurs for the laminated curved panel with fibers parallel to loading than in perpendicular direction. Fig. 8 shows the variations in the dynamic instability region of curved panels with a cutout size $c/a = 0.5$ for two layups. The onset of instability occurs earlier for a two layer angle ply layup ($45^\circ/-45^\circ$) than the eight layer symmetric angle ply [$45^\circ/-45^\circ/-45^\circ/45^\circ$]₂. This may be due to the effect of bending stretching coupling for the case of laminates.

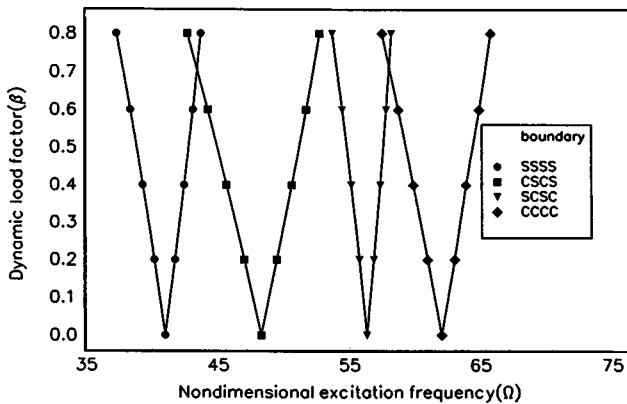

Fig. 5. Effect of boundary conditions (SSSS, CSCS, SCSC, CCCC) on instability region of curved panel for $a/b = 1, a/R_x = 0.0, b/R_y = 0.25, c/a = 0.3$, and $\alpha = 0.2$

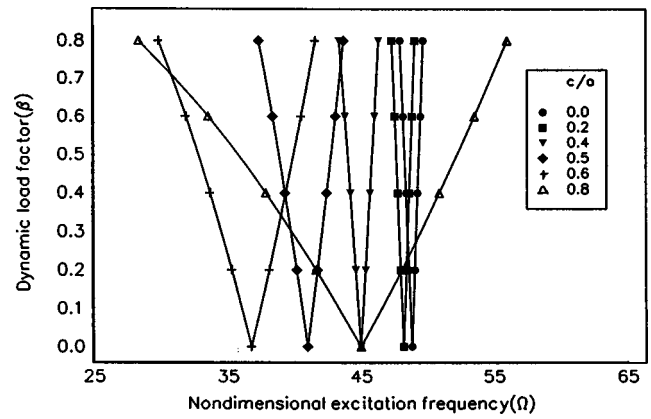

Fig. 6. Effect of size of cutout on instability region of simply supported cylindrical panel for $c/a = 0, 0.2, 0.4, 0.5, 0.6$, and $0.8, a/R_x = 0, b/R_y = 0.25$, and $\alpha = 0.2$

Conclusion

The dynamic stability of laminated composite curved panels with cutouts is investigated using the finite element method. Based on the parametric studies, the conclusions are

1. The excitation frequency decreases with the introduction of a cutout in laminated composite flat panels. With a further increase of size of the cutout, the onset of instability occurs later but with wider instability regions. This may be due to reduction of mass and predominance of boundary restraints at the edges.
2. The onset of instability occurs later for a composite curved panel by introducing curvatures. The laminated hyperbolic paraboloid shows highest excitation frequencies out of all geometries considered.
3. Instability occurs earlier with an increase of the static compressive in-plane load with wider dynamic instability regions for the composite curved panels with cutouts.
4. For any laminated cylindrical panel, the excitation frequency reduces with increasing cutout size. With an increase of size of the cutout, the effect of curvature is reduced for which the onset of instability occurs earlier. On further increase of the cutout, the effect of curvature is reduced and the curved panel behaves like a flat panel and the excitation frequency increases drastically.

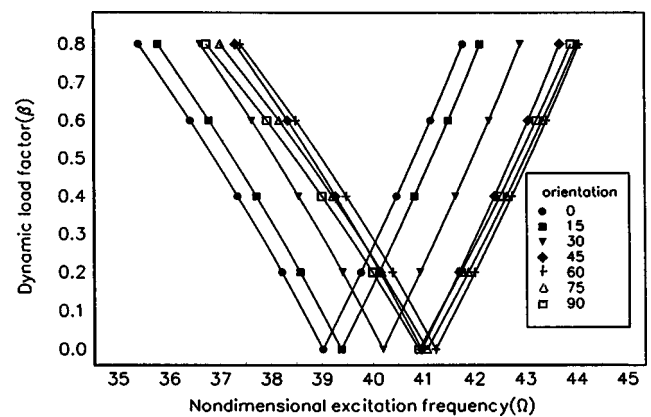

Fig. 7. Effect of ply orientation on instability region of curved panel $c/a = 0.5, a/R_x = 0, b/R_y = 0.25$, and $\alpha = 0.2$

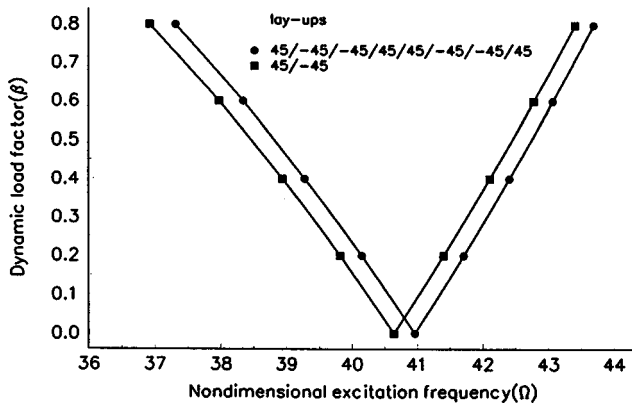

Fig. 8. Effect of ply lay-up on instability region of curved panel $c/a=0.5$, $a/R_x=0$, $b/R_y=0.25$, and $\alpha=0.2$

5. The excitation frequency increases due to restraint provided at the edges of the laminated curved panel with a cutout. The onset of instability occurs later for composite curved panels with restraints at the straight edges than restraints at the curved boundary.
6. The instability of composite curved panels with cutouts is influenced by the lamination parameters and preferential ply orientation is suggested.

From the above studies, it can be concluded that the instability behavior of laminated curved panels with geometrical discontinuity is greatly influenced by the size of the cutout, geometry, ply layup, and orientation and boundary conditions. So the designer has to be cautious while dealing with curved panels with cutouts subjected to periodic loading. This can be used to the advantage of tailoring during design of composite structures.

Notation

The following symbols are used in this paper:

- a, b = dimensions of shell;
- c, d = dimensions of cutout;
- E_{11}, E_{22} = Young's modulus;
- G_{12}, G_{13}, G_{23} = shear modulus;
- $[K]$ = stiffness matrix;
- $[K_g]$ = geometric stiffness matrix;
- $[M]$ = mass matrix;
- N_{cr} = critical buckling load;
- $\{q\}$ = vector of generalized coordinates;
- R_x, R_y = radii of curvature of shell;
- R_{xy} = radius of curvature of twist;
- w = deflection of midplane of doubly curved panel;
- α, β = static and dynamic load factors;
- θ_x, θ_y = rotations about axes;
- ν_{12}, ν_{21} = Poisson's ratio;
- ρ = mass density;
- $\sigma_x, \sigma_y, \tau_{xy}$ = initial in-plane stresses; and
- Ω, ω = frequency of forcing function and transverse vibration.

References

- Argento, A., and Scott, R. A. (1993). "Dynamic instability of layered anisotropic circular cylindrical shells. II: Numerical results." *J. Sound Vib.*, 162, 323–332.
- Bailey, R., and Wood, J. (1996). "Stability characteristics of composite panels with various cutout geometries." *Compos. Struct.*, 35, 21–31.
- Bolotin, V. V. (1964). *The dynamic stability of elastic systems*, Holden-Day, San Francisco.
- Cederbaum, G. (1992). "Analysis of parametrically excited laminated shells." *Int. J. Mech. Sci.*, 34(3), 241–250.
- Chakravorty, D., Sinha, P. K., and Bandyopadhyay, J. N. (1998). "Applications of FEM on free and forced vibration of laminated shells." *J. Eng. Mech.*, 124(1), 1–8.
- Chandrashekhara, K. (1989). "Free vibrations of anisotropic laminated doubly curved shells." *Comput. Struct.*, 33, 435–440.
- Chen, C. C., Kitipornchai, S., Lim, C. W., and Liew, K. M. (2000). "Free vibration of symmetrically laminated thick perforated plates." *J. Sound Vib.*, 230(1), 111–132.
- Evan-iwanowski, R. M. (1965). "On the parametric response of structures." *Appl. Mech. Rev.*, 18, 699–702.
- Ganapathi, M., Patel, B. P., and Sambandam, C. T. (1999). "Parametric dynamic instability analysis of laminated composite conical shells." *J. Reinf. Plast. Compos.*, 18(14), 1336–1346.
- Ganapathi, M., Varadan, T. K., and Balamurugan, V. (1994). "Dynamic stability of laminated composite curved panels using finite element method." *Comput. Struct.*, 53(2), 335–342.
- Ibrahim, R. A. (1978). "Parametric vibration. III: Current problems (1)." *Shock Vib. Dig.*, 10, 41–57.
- Jenq, S. T., Hwang, G. C., and Yang, S. M. (1993). "The effect of square cutouts on the natural frequencies and mode shapes of GRP cross-ply laminates." *Compos. Sci. Technol.*, 47, 91–101.
- Ko, W. L. (1998). "Anomalous buckling characteristics of laminated metal-matrix composite plates with central square holes." *NASA Technical Paper*, 206559, 1–10.
- Lee, H. P., and Lim, S. P. (1992). "Free vibration of isotropic and orthotropic square plates with square cut outs subjected to in-plane forces." *Comput. Struct.*, 43(3), 431–437.
- Lee, H. P., Lim, S. P., and Chow, S. T. (1987). "Free vibration of composite rectangular plates with rectangular cutouts." *Comput. Struct.*, 8, 63–81.
- Lee, H. P., Lim, S. P., and Chow, S. T. (1992). "Effect of transverse shear deformation and rotary inertia on the natural frequencies of rectangular plates with cutouts." *Int. J. Solids Struct.*, 29(11), 1351–1359.
- Leissa, A. W., and Qatu, M. S. (1991). "Equations of elastic deformation of laminated composite shallow shells." *J. Appl. Mech.*, 58, 181–188.
- Lin, C. C., and Kuo, C. S. (1989). "Buckling of laminated plates with holes." *J. Compos. Mater.*, 23, 536–553.
- Moorthy, J., Reddy, J. N., and Plaut, R. H. (1990). "Parametric instability of laminated composite plates with transverse shear deformation." *Int. J. Solids Struct.*, 26, 801–811.
- Nemeth, M. P. (1988). "Buckling behavior of compression loaded symmetrically laminated angle-ply plates with holes." *AIAA J.*, 26, 330–336.
- Nemeth, M. P. (1996). "Buckling and post-buckling behavior of laminated composite plates with a cutout." *NASA Technical Paper*, 3587, 1–23.
- Ng, T. Y., Lam, K. Y., and Reddy, J. N. (1998). "Dynamic stability of cross-ply laminated composite cylindrical shells." *Int. J. Mech. Sci.*, 40(8), 805–823.
- Rajamani, A., and Prabhakaran, R. (1977a). "Dynamic response of composite plates with cut-outs, part I: simply supported plates." *J. Sound Vib.*, 54(4), 549–564.
- Rajamani, A., and Prabhakaran, R. (1977b). "Dynamic response of composite plates with cut-outs, part II: clamped clamped plates." *J. Sound Vib.*, 54(4), 565–576.
- Reddy, J. N. (1982). "Large amplitude flexural vibration of layered composite plates with cutouts." *J. Sound Vib.*, 1, 1–10.
- Sahu, S. K., and Datta, P. K. (2001a). "Parametric resonance characteristics of laminated composite doubly curved shells subjected to non-

- uniform loading." *J. Reinf. Plast. Compos.*, 20(18), 1556–1576.
- Sahu, S. K., and Datta, P. K. (2001b). "Parametric instability of doubly curved panels subjected to non-uniform harmonic loading." *J. Sound Vib.*, 240(1), 117–129.
- Sahu, S. K., and Datta, P. K. (2002). "Dynamic stability of curved panels with cutouts." *J. Sound Vib.*, 254(4), 683–696.
- Simitses, G. J. (1987). "Instability of dynamically loaded structures." *Appl. Mech. Rev.*, 40, 1403–1408.
- Sivakumar, K., Iyengar, N. G. R., and Deb, K. (1999). "Free vibration of laminated composite plates with cutout." *J. Sound Vib.*, 221, 443–470.
- Srivatsa, K. S., and Murty, A. V. K. (1992). "Stability of laminated composite plates with cutouts." *Comput. Struct.*, 43, 273–279.
- Vellaichamy, S., Prakash, B. G., and Brun, S. (1990). "Optimum design of cutouts in laminated composite structures." *Comput. Struct.*, 37(3), 241–246.